

LOT 282 NEW VALMEYER PHASE 5

VALMEYER IL 62295

Site Address: 000100 DEER CT

BLDG # 1  
 Style/Stories 2.0 2 Story  
 Quality/Design C C-Average  
 Building Use 0100 Single Fami  
 Exterior Wall M Masonry 2.0  
 WALL % 080 080%  
 Exterior Wall 1 F Frame  
 WALL 1% 020 020%  
 Crawl Sp. Adj  
 Slab Adjustment  
 Basement  
 Combination M1 Masonry/1.0  
 Attic Area  
 Heat/AC Adj AC Central Air  
 Comb Ht/AC Adj AC1 Cent AC Cmb  
 Fireplace 23 C-2 Fr.Pl/2  
 Extra Fireplace 00 N/A  
 Res Fixtures 0011 11 Fixtures  
 Garage M Masonry Gar  
 Integral Garage  
 Remodeling Adj 01 No Remodeli  
 Actual Year Blt 1995  
 Effect Year Blt 1995  
 Cond/Desir/Util A Res CDU - A  
 Township Multpl 06 TOWNSHIP #0  
 Funct. Obs. % 000000  
 Economic Obs. % 000000  
 Observed Cond % 000000  
 Obs. Cond. Code  
 Combination A  
 Comb A Ht/AC  
 Unfin Low/Level  
 Full Basement F Full Baseme  
 # Of Bedrooms 04 Four Bedroo  
 Sq.Ft.Gr'd Area 1924 ASP

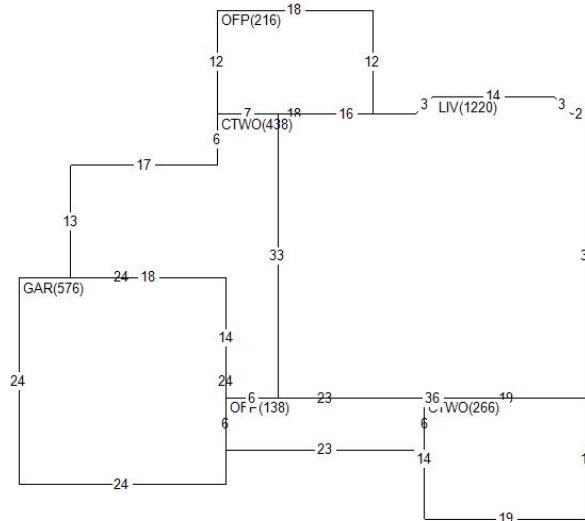

Land Value 26,760  
 Misc Value 21,590  
 Bldg Value 192,630  
 Total Value 240,980  
 Value By CAMA

RCN 234,913  
 Pct Good 0.8200  
 Obsol/Observed 0.0000  
 Building Value 192,630

DOCUMENT # DATE QS SALE PRICE  
 1194 U 11,319

PERMIT NO TYPE DATE AMOUNT  
 R1-95-20 01 0795

Appraiser KS K. Sondag  
 Appr Date 07/06/22  
 Use Code 0040 Imp Res  
 NBHD 62000.20 VLMYR 2.0 STORY  
 L100 M100 B100

AREA	FLAT	EFF% E/AREA	ACT% A/AREA	EA/AA HEATED
OFFP	354	1.00	354 1.00	354 354
CTWO	704	1.00	704 1.00	704 704
GAR	576	1.00	576 1.00	576 576
LIV	1220	1.00	1220 1.00	1220 1220
ASP	1656	1.00	1656 1.00	1656 1656

MISC BLDG CODE	DESC	LENGTH	WIDTH	UNITS	ADJ PRICE	EYB DT PCT	ADJUSTMENT	VALUE
1 1 OFFP	Open Frame Porch	6.00	23.00	138.00	24.58	1995 A 18.00	1.00	2,780
2 1 OFFP	Open Frame Porch	12.00	18.00	216.00	23.09	1995 A 18.00	1.00	4,090
3 1 GARF	Garage Frame	30.00	24.00	720.00	19.22	1990 A 23.00	1.00	10,660
4 1 ASP	Asphalt Driveway	69.00	24.00	1656.00	2.85	1999 A 14.00	1.00	4,060

LAND LUSE DESC	ZONING	UNITS TP	PRICE	ADJUSTMENT	CODE/FACTOR	VALUE
1 6200 VALMEYER	VR1	1.00 ST	26760.00	.00	.00 TW 1.00	26,760