

LOT 289 NEW VALMEYER PHASE 5

VALMEYER IL 62295

Site Address: 000328 N CEDAR BLUFF DR

BLDG # 1
 Style/Stories 1.0 One Story
 Quality/Design C C-Average
 Building Use 0100 Single Fami
 Exterior Wall F Frame
 WALL % 070 070%
 Exterior Wall 1 M Masonry
 WALL 1% 030 030%
 Crawl Sp. Adj C Crawl
 Slab Adjustment
 Basement
 Combination
 Attic Area
 Heat/AC Adj AC Central Air
 Comb Ht/AC Adj
 Fireplace 00 N/A
 Extra Fireplace 00 N/A
 Res Fixtures 0010 10 Fixtures
 Garage F Frame Garag
 Integral Garage
 Remodeling Adj 01 No Remodeli
 Actual Year Blt 1999
 Effect Year Blt 1999
 Cond/Desir/Util A Res CDU - A
 Township Multpl 06 TOWNSHIP #0
 Funct. Obs. % 000000
 Economic Obs. % 000000
 Observed Cond % 000000
 Obs. Cond. Code
 Combination A
 Comb A Ht/AC
 Unfin Low/Level
 Full Basement F Full Baseme
 # Of Bedrooms 02 Two Bedroom
 Sq.Ft.Grd Area 1424

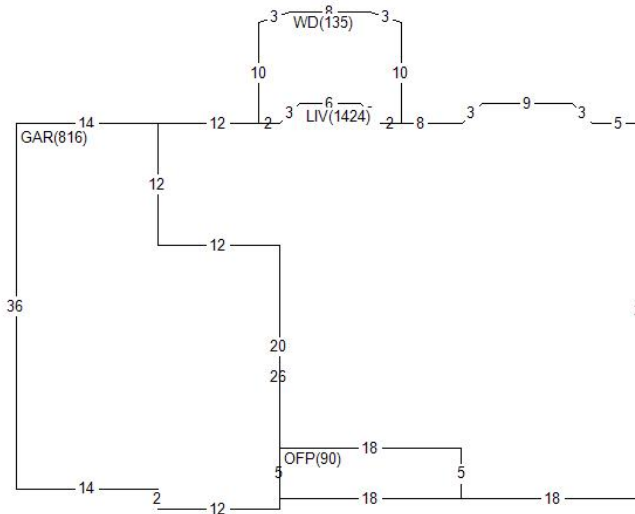

Land Value 26,760
 Misc Value 15,830
 Bldg Value 159,020
 Total Value 201,610
 Value By CAMA

RCN 184,910
 Pct Good 0.8600
 Obsol/Observed 0.0000
 Building Value 159,020

DOCUMENT #	DATE	QS	SALE PRICE
1094	U		9,256

PERMIT NO	TYPE	DATE	AMOUNT
R1-03-10	04	0303	
R1-98-10	00	0599	
R1-98-10	01	0698	

Appraiser KS K. Sondag
 Appr Date 07/06/22
 Use Code 0040 Imp Res
 NBHD 62000.10 VLMYR 1.0 STORY
 L100 M100 B144

AREA	FLAT	EFF% E/AREA	ACT% A/AREA	EA/AA HEATED
OFF	90	1.00	90	90
GAR	816	1.00	816	816
WD	135	1.00	135	135
LIV	1424	1.00	1424	1424
CONDR	1192	1.00	1192	1192
CRWL	38	1.00	38	38

MISC BLDG CODE	DESC	LENGTH	WIDTH	UNITS	ADJ PRICE	EYB DT PCT	ADJUSTMENT	VALUE
1	1 OFF	5.00	18.00	90.00	28.19	1999 A 14.00	1.00	2,180
2	1 CONDR	.00	.00	1192.00	3.65	1999 A 14.00	1.00	3,740
3	1 BRVEN	.00	.00	600.00	14.65	1999 A 14.00	1.00	7,560
4	1 WD	.00	.00	135.00	19.35	2004 A 10.00	1.00	2,350

LAND LUSE DESC	ZONING	UNITS TP	PRICE	ADJUSTMENT	CODE/FACTOR	VALUE
1 6200 VALMEYER	VR1	1.00 ST	26760.00	.00	.00 TW 1.00	26,760