

LOT 295 NEW VALMEYER PHASE 5

VALMEYER IL 62295

Site Address: 000203 FALCON POINTE DR

BLDG # 1
 Style/Stories 1.0 One Story
 Quality/Design C C-Average
 Building Use 0100 Single Fami
 Exterior Wall F Frame
 WALL % 100 100%
 Exterior Wall 1
 WALL 1% 000 N/A
 Crawl Sp. Adj
 Slab Adjustment
 Basement
 Combination
 Attic Area
 Heat/AC Adj AC Central Air
 Comb Ht/AC Adj
 Fireplace 00 N/A
 Extra Fireplace 00 N/A
 Res Fixtures 0008 08 Fixtures
 Garage F Frame Garag
 Integral Garage
 Remodeling Adj 01 No Remodeli
 Actual Year Blt 2005
 Effect Year Blt 2005
 Cond/Desir/Util A Res CDU - A
 Township Multpl 06 TOWNSHIP #0
 Funct. Obs. % 000000
 Economic Obs. % 000000
 Observed Cond % 000000
 Obs. Cond. Code
 Combination A
 Comb A Ht/AC
 Unfin Low/Level
 Full Basement F Full Baseme
 # Of Bedrooms 03 Three Bedro
 Sq.Ft.Grd Area 1362

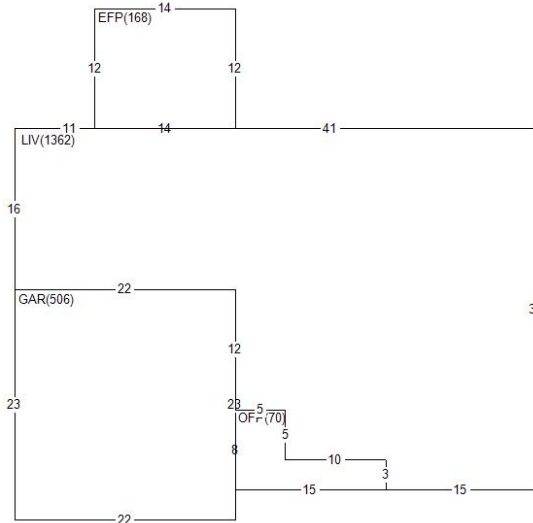

Land Value 26,760
 Misc Value 18,050
 Bldg Value 149,310
 Total Value 194,120
 Value By CAMA

RCN 164,074
 Pct Good 0.9100
 Obsol/Observed 0.0000
 Building Value 149,310

DOCUMENT #	DATE	QS	SALE PRICE
327790	1208	Q	157,500
303164	1205	Q	162,025
299658	0805	Q	42,000

PERMIT NO	TYPE	DATE	AMOUNT
R1-13-03	07	0713	
R1-08-13	02	1208	
R1-05-24	01	0805	

Appraiser KS K. Sondag
 Appr Date 07/07/22
 Use Code 0040 Imp Res
 NBHD 62000.10 VLMYR 1.0 STORY
 L100 M100 B144

AREA	FLAT	EFF%	E/AREA	ACT%	A/AREA	EA/AA	HEATED
CONDR	666	1.00	666	1.00	666	666	
GZBO	82	1.00	82	1.00	82	82	
OFF	70	1.00	70	1.00	70	70	
GAR	506	1.00	506	1.00	506	506	
EFP	168	1.00	168	1.00	168	168	
LIV	1362	1.00	1362	1.00	1362	1362	1362

MISC BLDG CODE	DESC	LENGTH	WIDTH	UNITS	ADJ PRICE	EYB DT PCT	ADJUSTMENT	VALUE
2 1 OFFP	Open Frame Porch	.00	.00	70.00	30.94	2005 A 9.00	1.00	1,970
3 1 CONDR	Concrete Drivewa	37.00	18.00	666.00	3.65	2005 A 9.00	1.00	2,210
5 1 GZBO	Gazebo	.00	.00	82.00	29.14	2009 A 6.00	1.00	2,250
6 1 EFP	Enclosed Fr. Por	12.00	14.00	168.00	40.88	2013 A 3.00	1.00	6,660
7 1 SHED	Frame Shed	16.00	12.00	192.00	26.36	2017 A 2.00	1.00	4,960

LAND LUSE DESC	ZONING	UNITS TP	PRICE	ADJUSTMENT	CODE/FACTOR	VALUE
1 6200 VALMEYER	VR1	1.00 ST	26760.00	.00	.00 TW 1.00	26,760