

LOT 324 NEW VALMEYER PHASE 5

VALMEYER IL 62295  
Site Address: 000313 FALCON POINTE

BLDG # 1  
 Style/Stories 1.0 One Story  
 Quality/Design C C-Average  
 Building Use 0100 Single Fami  
 Exterior Wall F Frame  
 WALL % 100 100%  
 Exterior Wall 1  
 WALL 1% 000 N/A  
 Crawl Sp. Adj  
 Slab Adjustment  
 Basement RC C-Rec Room  
 Combination  
 Attic Area  
 Heat/AC Adj AC Central Air  
 Comb Ht/AC Adj  
 Fireplace 31 DirectVent  
 Extra Fireplace 00 N/A  
 Res Fixtures 0008 08 Fixtures  
 Garage F Frame Garag  
 Integral Garage  
 Remodeling Adj 01 No Remodeli  
 Actual Year Blt 2003  
 Effect Year Blt 2003  
 Cond/Desir/Util A  
 Township Multpl 06 Res CDU - A  
 Funct. Obs. % TOWNSHIP #0  
 Economic Obs. %  
 Observed Cond %  
 Obs. Cond. Code  
 Combination A  
 Comb A Ht/AC  
 Unfin Low/Level  
 Full Basement F Full Baseme  
 # Of Bedrooms 03 Three Bedro  
 Sq.Ft.Grd Area 1672

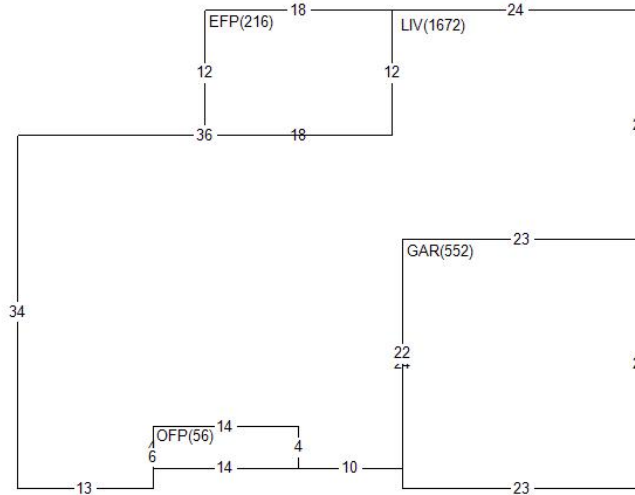

Land Value 26,760  
 Misc Value 13,290  
 Bldg Value 173,950  
 Total Value 214,000  
 Value By CAMA

RCN 195,445  
 Pct Good 0.8900  
 Obsol/Observed 0.0000  
 Building Value 173,950

DOCUMENT #	DATE	QS	SALE PRICE
0799	Q		20,500
0895	U		6,580
0595	U		

PERMIT NO	TYPE	DATE	AMOUNT
R1-03-12	01	0403	

Appraiser KS K. Sondag  
 Appr Date 07/07/22  
 Use Code 0040 Imp Res  
 NBHD 62000.10 VLMYR 1.0 STORY  
 L100 M100 B144

AREA	FLAT	EFF%	E/AREA	ACT%	A/AREA	EA/AA	HEATED
CONDR	480	1.00	480	1.00	480	480	
BSMR	288	1.00	288	1.00	288	288	
OFFP	56	1.00	56	1.00	56	56	
GAR	552	1.00	552	1.00	552	552	
EFP	216	1.00	216	1.00	216	216	
LIV	1672	1.00	1672	1.00	1672	1672	1672

MISC BLDG CODE	DESC	LENGTH	WIDTH	UNITS	ADJ PRICE	EYB DT	PCT	ADJUSTMENT	VALUE
1 1 OFFP	Open Frame Porch	4.00	14.00	56.00	34.00	2003 A	11.00	1.00	1,700
2 1 EFP	Enclosed Fr. Por	12.00	18.00	216.00	39.15	2003 A	11.00	1.00	7,530
3 1 CONDR	Concrete Drivewa	24.00	20.00	480.00	3.65	2003 A	11.00	1.00	1,560
4 1 BRVEN	Brick Veneer	.00	.00	192.00	14.65	2003 A	11.00	1.00	2,500

LAND LUSE DESC	ZONING	UNITS TP	PRICE	ADJUSTMENT	CODE/FACTOR	VALUE
1 6200 VALMEYER	VR1	1.00 ST	26760.00	.00	.00 TW 1.00	26,760