

LOT 168 NEW VALMEYER PHASE 3

VALMEYER IL 62295  
 Site Address: 000210 W WOODLAND RIDGE

BLDG # 1  
 Style/Stories 2.0 2 Story  
 Quality/Design C C-Average  
 Building Use 0100 Single Fami  
 Exterior Wall F Frame 2.0  
 WALL % 100 100%  
 Exterior Wall 1  
 WALL 1% 000 N/A  
 Crawl Sp. Adj  
 Slab Adjustment  
 Basement RC C-Rec Room  
 Combination F1 Frame/1.0  
 Attic Area  
 Heat/AC Adj AC Central Air  
 Comb Ht/AC Adj AC1 Cent AC Cmb  
 Fireplace 03 C-Fireplace  
 Extra Fireplace 00 N/A  
 Res Fixtures 0013 13 Fixtures  
 Garage F Frame Garag  
 Integral Garage  
 Remodeling Adj 01 No Remodeli  
 Actual Year Blt 1994  
 Effect Year Blt 1994  
 Cond/Desir/Util A Res CDU - A  
 Township Multpl 09 TOWNSHIP #0  
 Funct. Obs. % 000000  
 Economic Obs. % 000000  
 Observed Cond % 000000  
 Obs. Cond. Code  
 Combination A  
 Comb A Ht/AC  
 Unfin Low/Level  
 Full Basement F Full Baseme  
 # Of Bedrooms 05 Five Bedroo  
 Sq.Ft.Grđ Area 1711

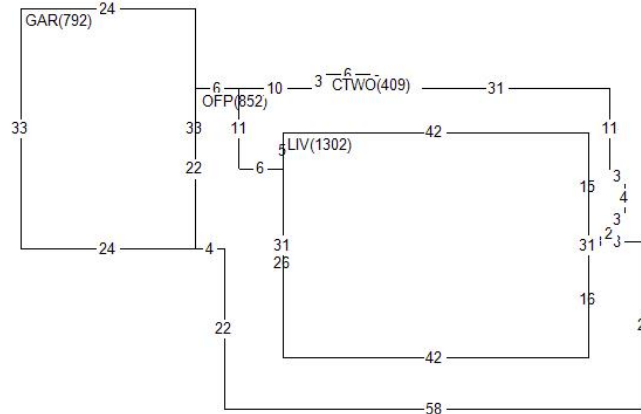

Land Value 26,760  
 Misc Value 20,860  
 Bldg Value 168,090  
 Total Value 215,710  
 Value By CAMA

RCN 204,988  
 Pct Good 0.8200  
 Obsol/Observed 0.0000  
 Building Value 168,090

DOCUMENT # DATE QS SALE PRICE  
 0994 U 14,983

PERMIT NO TYPE DATE AMOUNT  
 R1-01-04 21 0301  
 R1-94-22 01 1094

Appraiser KS K. Sondag  
 Appr Date 07/20/22  
 Use Code 0040 Imp Res  
 NBHD 62000.20 VLMYR 2.0 STORY  
 L100 M100 B094

AREA	FLAT	EFF%	E/AREA	ACT%	A/AREA	EA/AA	HEATED
CONDR	1749	1.00	1749	1.00	1749	1749	
BSMR	805	1.00	805	1.00	805	805	
GAR	792	1.00	792	1.00	792	792	
OFFP	852	1.00	852	1.00	852	852	
CTWO	409	1.00	409	1.00	409	409	
LIV	1302	1.00	1302	1.00	1302	1302	1302

MISC BLDG CODE	DESC	LENGTH	WIDTH	UNITS	ADJ PRICE	EYB DT PCT	ADJUSTMENT	VALUE
1 1 OFFP	Open Frame Porch	.00	.00	852.00	20.03	1994 A 18.00	1.00	13,990
2 1 CONDR	Concrete Drivewa	53.00	33.00	1749.00	3.65	1995 A 17.00	1.00	5,300
3 1 PTO	Concrete Patio	.00	.00	434.00	3.65	2019 A 1.00	1.00	1,570

LAND LUSE DESC	ZONING	UNITS TP	PRICE	ADJUSTMENT	CODE/FACTOR	VALUE
1 6200 VALMEYER	VR1	1.00 ST	26760.00	.00	.00 TW 1.00	26,760