

LOT 181 NEW VALMEYER PHASE 3

VALMEYER IL 62295  
Site Address: 000226 W WOODLAND RIDGE

BLDG # 1  
 Style/Stories 2.0 2 Story  
 Quality/Design C C-Average  
 Building Use 0100 Single Fami  
 Exterior Wall F Frame 2.0  
 WALL % 100 100%  
 Exterior Wall 1  
 WALL 1% 000 N/A  
 Crawl Sp. Adj C Crawl  
 Slab Adjustment  
 Basement RC C-Rec Room  
 Combination  
 Attic Area  
 Heat/AC Adj AC Central Air  
 Comb Ht/AC Adj  
 Fireplace 03 C-Fireplace  
 Extra Fireplace 00 N/A  
 Res Fixtures 0011 11 Fixtures  
 Garage F Frame Garag  
 Integral Garage  
 Remodeling Adj 01 No Remodeli  
 Actual Year Blt 1995  
 Effect Year Blt 1995  
 Cond/Desir/Util A Res CDU - A  
 Township Multpl 09 TOWNSHIP #0  
 Funct. Obs. % 000000  
 Economic Obs. % 000000  
 Observed Cond % 000000  
 Obs. Cond. Code  
 Combination A  
 Comb A Ht/AC  
 Unfin Low/Level  
 Full Basement F Full Baseme  
 # Of Bedrooms 04 Four Bedroo  
 Sq.Ft.Grđ Area 1331

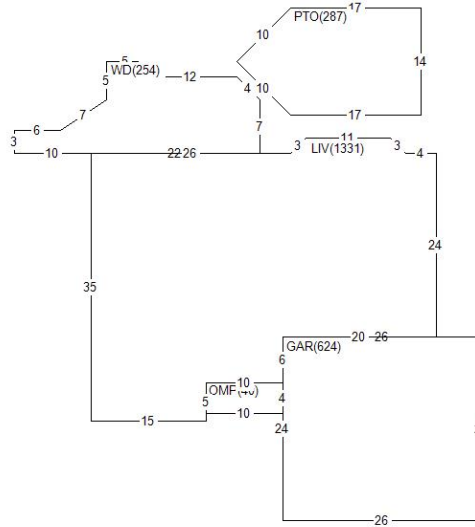

Land Value 26,760  
 Misc Value 24,060  
 Bldg Value 142,250  
 Total Value 193,070  
 Value By CAMA

RCN 171,384  
 Pct Good 0.8300  
 Obsol/Observed 0.0000  
 Building Value 142,250

DOCUMENT #	DATE	QS	SALE PRICE
0502	Q		202,500
1094	U		11,272

PERMIT NO	TYPE	DATE	AMOUNT
R1-12-10	02	1012	
R1-02-22	08	0702	
R1-95-03	01	0295	

Appraiser KS K. Sondag  
 Apr Date 07/20/22  
 Use Code 0040 Imp Res  
 NBHD 62000.20 VLMYR 2.0 STORY  
 L100 M100 B094

AREA	FLAT	EFF% E/AREA	ACT% A/AREA	EA/AA	HEATED
CONDR	1866	1.00	1866	1.00	1866
CRWL	26	1.00	26	1.00	26
BSMR	666	1.00	666	1.00	666
SHED	224	1.00	224	1.00	224
GAR	624	1.00	624	1.00	624
OMP	40	1.00	40	1.00	40
WD	254	1.00	254	1.00	254
LIV	1331	1.00	1331	1.00	1331
PTO	287	1.00	287	1.00	287

MISC BLDG CODE	DESC	LENGTH	WIDTH	UNITS	ADJ PRICE	EYB DT PCT	ADJUSTMENT	VALUE
1 1 BRVEN	Brick Veneer	.00	.00	464.00	14.65	1995 A 17.00	1.00	5,640
2 1 OMP	Open Masonry Por	4.00	10.00	40.00	47.50	1995 A 17.00	1.00	1,580
3 1 CONDR	Concrete Drivewa	.00	.00	1866.00	3.65	1995 A 17.00	1.00	5,650
5 1 WD	Wood Deck	.00	.00	254.00	19.35	2003 A 10.00	1.00	4,420
6 1 SHED	Frame Shed	8.00	8.00	64.00	26.79	2009 A 5.00	1.00	1,630
7 1 SHED	Frame Shed	10.00	16.00	160.00	26.47	2013 A 3.00	1.00	4,110

LAND LUSE DESC	ZONING	UNITS TP	PRICE	ADJUSTMENT	CODE/FACTOR	VALUE
1 6200 VALMEYER	VR1	1.00 ST	26760.00	.00	.00 TW 1.00	26,760

MISC BLDG CODE	DESC	Site Address:	VALMEYER	WOODLAND RIDGE	IL 62295	LENGTH	WIDTH	UNITS	ADJ PRICE	EYB DT	PCT	ADJUSTMENT	VALUE
8 1 PTO	Concrete Patio	000226 W				.00	.00	287.00	3.65	2015 A	2.00	1.00	1,030