

LOT 116 NEW VALMEYER PHASE 2

VALMEYER IL 62295  
Site Address: 000308 NELLIES RIDGE

BLDG # 1  
 Style/Stories 1.0 One Story  
 Quality/Design C C-Average  
 Building Use 0100 Single Fami  
 Exterior Wall F Frame  
 WALL % 100 100%  
 Exterior Wall 1  
 WALL 1% 000 N/A  
 Crawl Sp. Adj C Crawl  
 Slab Adjustment  
 Basement RC C-Rec Room  
 Combination  
 Attic Area  
 Heat/AC Adj AC Central Air  
 Comb Ht/AC Adj  
 Fireplace 03 C-Fireplace  
 Extra Fireplace 00 N/A  
 Res Fixtures 0011 11 Fixtures  
 Garage F Frame Garag  
 Integral Garage  
 Remodeling Adj 01 No Remodeli  
 Actual Year Blt 1997  
 Effect Year Blt 1997  
 Cond/Desir/Util A Res CDU - A  
 Township Multpl 09 TOWNSHIP #0  
 Funct. Obs. % 000000  
 Economic Obs. % 000000  
 Observed Cond % 000000  
 Obs. Cond. Code  
 Combination A  
 Comb A Ht/AC  
 Unfin Low/Level  
 Full Basement F Full Baseme  
 # Of Bedrooms 03 Three Bedro  
 Sq.Ft.Grđ Area 1076

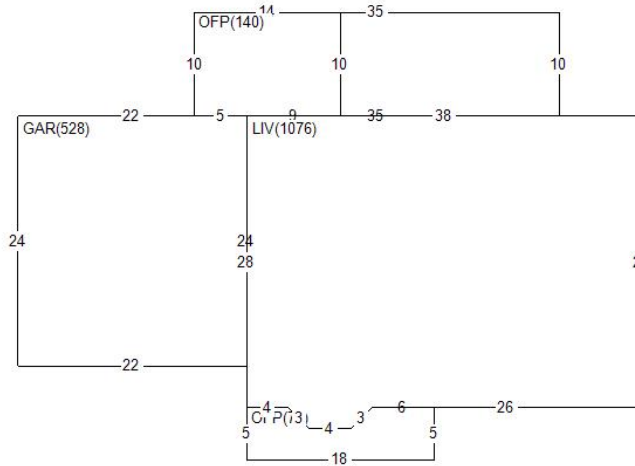

Land Value 26,760  
 Misc Value 8,370  
 Bldg Value 114,520  
 Total Value 149,650  
 Value By CAMA

RCN 134,729  
 Pct Good 0.8500  
 Obsol/Observed 0.0000  
 Building Value 114,520

DOCUMENT #	DATE	QS	SALE PRICE
0900	Q		119,000
0397	Q		15,400

PERMIT NO	TYPE	DATE	AMOUNT
R1-06-16	04	0606	
R1-01-05	08	0301	
R1-97-03	00	0697	

Appraiser KS K. Sondag  
 Appr Date 07/21/22  
 Use Code 0040 Imp Res  
 NBHD 62000.10 VLMYR 1.0 STORY  
 L100 M100 B118

AREA	FLAT	EFF%	E/AREA	ACT%	A/AREA	EA/AA	HEATED
BSMR	538	1.00	538	1.00	538	538	
CRWL	12	1.00	12	1.00	12	12	
CONDR	684	1.00	684	1.00	684	684	
OFFP	218	1.00	218	1.00	218	218	
PTO	350	1.00	350	1.00	350	350	
GAR	528	1.00	528	1.00	528	528	
LIV	1076	1.00	1076	1.00	1076	1076	1076

MISC BLDG CODE	DESC	LENGTH	WIDTH	UNITS	ADJ PRICE	EYB DT PCT	ADJUSTMENT	VALUE
1 1 OFFP	Open Frame Porch	.00	.00	78.00	29.69	1997 A 15.00	1.00	1,970
2 1 OFFP	Open Frame Porch	10.00	14.00	140.00	24.48	2006 A 7.00	1.00	3,190
3 1 PTO	Concrete Patio	10.00	35.00	350.00	3.65	1997 A 15.00	1.00	1,090
4 1 CONDR	Concrete Drivewa	38.00	18.00	684.00	3.65	1997 A 15.00	1.00	2,120

LAND LUSE DESC	ZONING	UNITS TP	PRICE	ADJUSTMENT	CODE/FACTOR	VALUE
1 6200 VALMEYER	VR1	1.00 ST	26760.00	TW 1.00	.00 .00	26,760