

LOT 114 NEW VALMEYER PHASE 2

VALMEYER IL 62295

Site Address: 000226 W HARRISONVILLE DR

BLDG # 1
Style/Stories 1.0 One Story
Quality/Design C C-Average
Building Use 0100 Single Fami
Exterior Wall F Frame
WALL % 100 100%
Exterior Wall 1
WALL 1% 000 N/A
Crawl Sp. Adj C Crawl
Slab Adjustment
Basement
Combination
Attic Area
Heat/AC Adj AC Central Air
Comb Ht/AC Adj
Fireplace 00 N/A
Extra Fireplace 00 N/A
Res Fixtures 0012 12 Fixtures
Garage F Frame Garag
Integral Garage
Remodeling Adj 01 No Remodeli
Actual Year Blt 2008
Effect Year Blt 2008
Cond/Desir/Util A Res CDU - A
Township Multpl 09 TOWNSHIP #0
Funct. Obs. %
Economic Obs. %
Observed Cond %
Obs. Cond. Code
Combination A
Comb A Ht/AC
Unfin Low/Level
Full Basement F Full Baseme
Of Bedrooms 03 Three Bedro
Sq.Ft.Grnd Area 1357

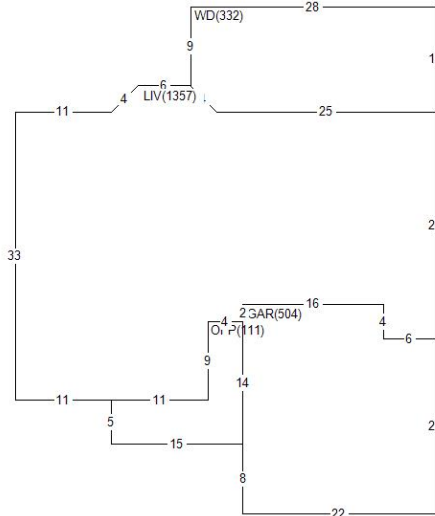

Land Value 26,760
Misc Value 17,340
Bldg Value 133,690
Total Value 177,790
Value By CAMA

RCN 142,227
Pct Good 0.9400
Obsol/Observed 0.0000
Building Value 133,690

DOCUMENT #	DATE	QS	SALE PRICE
319887	1107	Q	30,000
315740	0607	Q	16,200

PERMIT NO	TYPE	DATE	AMOUNT
R1-12-04	02	0612	

Appraiser KS K. Sondag
Appr Date 07/21/22
Use Code 0040 Imp Res
NBHD 62000.10 VLMYR 1.0 STORY
L100 M100 B118

AREA	FLAT	EFF%	E/AREA	ACT%	A/AREA	EA/AA	HEATED
CONDR	1200	1.00	1200	1.00	1200	1200	
CRWL	27	1.00	27	1.00	27	27	
OFFP	111	1.00	111	1.00	111	111	
GAR	504	1.00	504	1.00	504	504	
WD	332	1.00	332	1.00	332	332	
LIV	1357	1.00	1357	1.00	1357	1357	1357

MISC BLDG CODE	DESC	LENGTH	WIDTH	UNITS	ADJ PRICE	EYB DT	PCT	ADJUSTMENT	VALUE
1 1 WD	Wood Deck	.00	.00	332.00	19.35	2008 A	6.00	1.00	6,040
2 1 OFFP	Open Frame Porch	.00	.00	111.00	26.21	2008 A	6.00	1.00	2,730
3 1 CONDR	Concrete Drivewa	.00	.00	1200.00	3.65	2008 A	6.00	1.00	4,120
4 1 PTO	Concrete Patio	12.00	8.00	96.00	3.65	2013 A	3.00	1.00	340
5 1 SHED	Frame Shed	16.00	10.00	160.00	26.47	2013 A	3.00	1.00	4,110

LAND LUSE DESC	ZONING	UNITS TP	PRICE	ADJUSTMENT	CODE/FACTOR	VALUE
1 6200 VALMEYER	VR1	1.00 ST	26760.00	TW 1.00	.00 .00 .00	26,760