

LOT 123 NEW VALMEYER PHASE 2

VALMEYER IL 62295
Site Address: 000317 NELLIES RIDGE

BLDG # 1
 Style/Stories 1.0 One Story
 Quality/Design C C-Average
 Building Use 0100 Single Fami
 Exterior Wall F Frame
 WALL % 070 070%
 Exterior Wall 1 M Masonry
 WALL 1% 030 030%
 Crawl Sp. Adj
 Slab Adjustment
 Basement RC C-Rec Room
 Combination
 Attic Area
 Heat/AC Adj AC Central Air
 Comb Ht/AC Adj
 Fireplace 00 N/A
 Extra Fireplace 00 N/A
 Res Fixtures 0012 12 Fixtures
 Garage M Masonry Gar
 Integral Garage
 Remodeling Adj 01 No Remodeli
 Actual Year Blt 1995
 Effect Year Blt 1995
 Cond/Desir/Util A
 Township Multpl 09 TOWNSHIP #0
 Funct. Obs. % 000000
 Economic Obs. % 000000
 Observed Cond % 000000
 Obs. Cond. Code
 Combination A
 Comb A Ht/AC
 Unfin Low/Level
 Full Basement F Full Baseme
 # Of Bedrooms 03 Three Bedro
 Sq.Ft.Grnd Area 1732

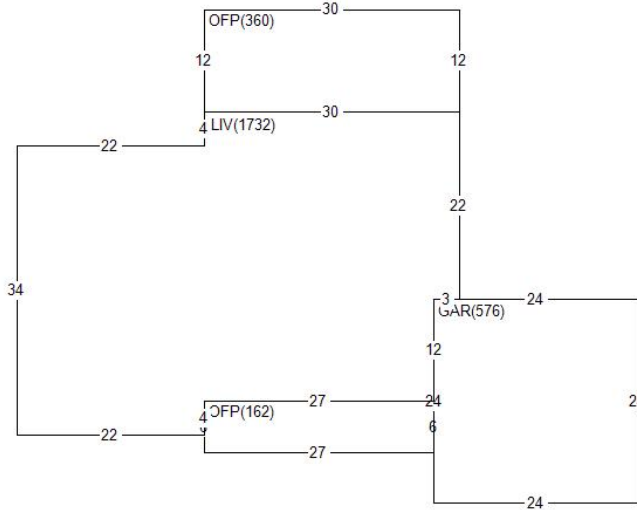

Land Value 26,760
 Misc Value 15,500
 Bldg Value 147,270
 Total Value 189,530
 Value By CAMA

RCN 177,434
 Pct Good 0.8300
 Obsol/Observed 0.0000
 Building Value 147,270

DOCUMENT #	DATE	QS	SALE PRICE
373847	1014	U	141,400
295821	0305	26	
	0994	U	5,653

PERMIT NO	TYPE	DATE	AMOUNT
R1-94-36	01	1094	

Appraiser KS K. Sondag
 Appr Date 07/21/22
 Use Code 0040 Imp Res
 NBHD 62000.10 VLMYR 1.0 STORY
 L100 M100 B118

AREA	FLAT	EFF% E/AREA	ACT% A/AREA	EA/AA HEATED
BSMR	704	1.00	704	704
CONDR	780	1.00	780	780
OFFP	522	1.00	522	522
GAR	576	1.00	576	576
LIV	1732	1.00	1732	1732

MISC BLDG CODE	DESC	LENGTH	WIDTH	UNITS	ADJ PRICE	EYB DT PCT	ADJUSTMENT	VALUE
1 1 OFFP	Open Frame Porch	6.00	27.00	162.00	23.73	1995 A 17.00	1.00	3,190
2 1 OFFP	Open Frame Porch	12.00	30.00	360.00	22.18	1995 A 17.00	1.00	6,630
3 1 CONDR	Concrete Drivewa	39.00	20.00	780.00	3.65	1995 A 17.00	1.00	2,360
5 1 CONDR	Concrete Drivewa	.00	.00	927.00	3.65	2015 A 2.00	1.00	3,320

LAND LUSE DESC	ZONING	UNITS TP	PRICE	ADJUSTMENT	CODE/FACTOR	VALUE
1 6200 VALMEYER	VR1	1.00 ST	26760.00	.00	.00 TW 1.00	26,760