

Req By: KRIS\_K  
HERCULES D KARAKATSANIS  
MARIA J KARAKATSANIS  
215 W HARRISONVILLE DR

LOT 129 NEW VALMEYER PHASE 2

VALMEYER IL 62295

Site Address: 000215 W HARRISONVILLE DR

BLDG # 1  
 Style/Stories 1.0 One Story  
 Quality/Design C C-Average  
 Building Use 0100 Single Fami  
 Exterior Wall F Frame  
 WALL % 100 100%  
 Exterior Wall 1  
 WALL 1% 000 N/A  
 Crawl Sp. Adj  
 Slab Adjustment  
 Basement  
 Combination  
 Attic Area  
 Heat/AC Adj AC Central Air  
 Comb Ht/AC Adj  
 Fireplace  
 Extra Fireplace 00 DirectVent  
 Res Fixtures 0010 10 Fixtures  
 Garage F Frame Garag  
 Integral Garage  
 Remodeling Adj 01 No Remodeli  
 Actual Year Blt 2004  
 Effect Year Blt 2004  
 Cond/Desir/Util A Res CDU - A  
 Township Multpl 09 TOWNSHIP #0  
 Funct. Obs. %  
 Economic Obs. %  
 Observed Cond %  
 Obs. Cond. Code  
 Combination A  
 Comb A Ht/AC  
 Unfin Low/Level  
 Full Basement F Full Baseme  
 # Of Bedrooms 03 Three Bedro  
 Sq.Ft.Grd Area 1544

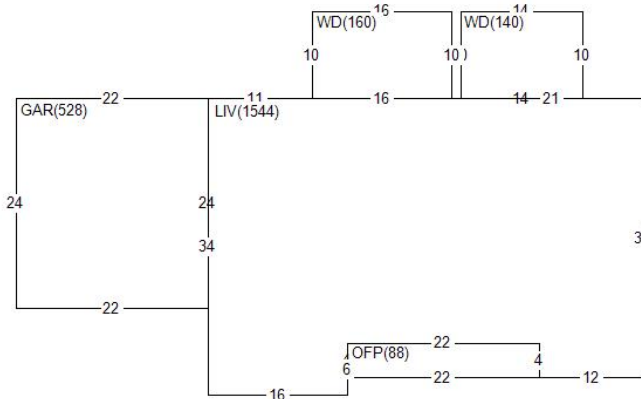

Land Value 26,760  
 Misc Value 16,390  
 Bldg Value 140,180  
 Total Value 183,330  
 Value By CAMA

RCN 154,042  
 Pct Good 0.9100  
 Obsol/Observed 0.0000  
 Building Value 140,180

DOCUMENT #	DATE	QS	SALE PRICE
363225	0313	Q	137,000
350746	0911	U	
349930	0811	U	
PERMIT NO	TYPE	DATE	AMOUNT
R1-04-16	01	0404	

Appraiser KS K. Sondag  
 Appr Date 07/21/22  
 Use Code 0040 Imp Res  
 NBHD 62000.10 VLMYR 1.0 STORY  
 L100 M100 B118

AREA	FLAT	EFF% E/AREA	ACT% A/AREA	EA/AA HEATED
CONDR	792	1.00	792	792
OFP	88	1.00	88	88
GAR	528	1.00	528	528
WD	300	1.00	300	300
LIV	1544	1.00	1544	1544

MISC BLDG CODE	DESC	LENGTH	WIDTH	UNITS	ADJ PRICE	EYB DT PCT	ADJUSTMENT	VALUE
1 1 BRVEN	Brick Veneer	.00	.00	464.00	14.65	2004 A 9.00	1.00	6,190
2 1 OFP	Open Frame Porch	4.00	22.00	88.00	28.43	2004 A 9.00	1.00	2,280
3 1 WD	Wood Deck	10.00	16.00	160.00	19.35	2004 A 9.00	1.00	2,820
4 1 WD	Wood Deck	10.00	14.00	140.00	19.35	2004 A 9.00	1.00	2,470
5 1 CONDR	Concrete Drivewa	44.00	18.00	792.00	3.65	2004 A 9.00	1.00	2,630

LAND LUSE DESC	ZONING	UNITS TP	PRICE	ADJUSTMENT	CODE/FACTOR	VALUE
1 6200 VALMEYER	VR1	1.00 ST	26760.00	TW 1.00	.00 .00	26,760