

LOT 94 NEW VALMEYER PHASE 2

COLUMBIA IL 62236

Site Address: 000105 ANDRES CT

BLDG # 1  
 Style/Stories 1.0 One Story  
 Quality/Design C C-Average  
 Building Use 0100 Single Fami  
 Exterior Wall F Frame  
 WALL % 100 100%  
 Exterior Wall 1  
 WALL 1% 000 N/A  
 Crawl Sp. Adj  
 Slab Adjustment  
 Basement  
 Combination  
 Attic Area  
 Heat/AC Adj AC Central Air  
 Comb Ht/AC Adj  
 Fireplace 00 N/A  
 Extra Fireplace 00 N/A  
 Res Fixtures 0008 08 Fixtures  
 Garage F Frame Garag  
 Integral Garage  
 Remodeling Adj 01 No Remodeli  
 Actual Year Blt 1996  
 Effect Year Blt 1996  
 Cond/Desir/Util A Res CDU - A  
 Township Multpl 09 TOWNSHIP #0  
 Funct. Obs. % 000000  
 Economic Obs. % 000000  
 Observed Cond % 000000  
 Obs. Cond. Code  
 Combination A  
 Comb A Ht/AC  
 Unfin Low/Level  
 Full Basement F Full Baseme  
 # Of Bedrooms 03 Three Bedro  
 Sq.Ft.Grd Area 1568

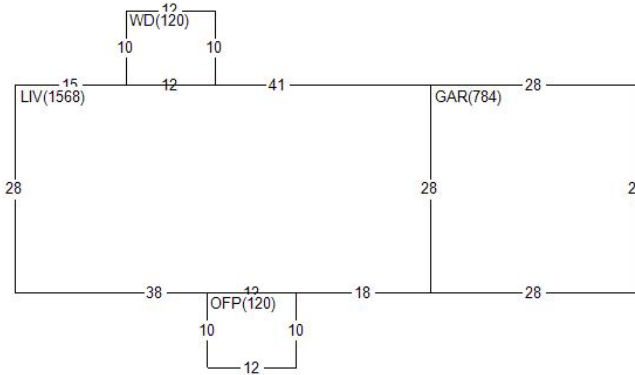

Land Value 26,760  
 Misc Value 8,440  
 Bldg Value 128,370  
 Total Value 163,570  
 Value By CAMA

RCN 152,823  
 Pct Good 0.8400  
 Obsol/Observed 0.0000  
 Building Value 128,370

DOCUMENT #	DATE	QS	SALE PRICE
371227	0514	U	
	0994	U	10,710

PERMIT NO	TYPE	DATE	AMOUNT
R1-96-04	00	0597	
R1-96-04	01	0396	

Appraiser KS K. Sondag  
 Appr Date 07/22/22  
 Use Code 0040 Imp Res  
 NBHD 62000.10 VLMYR 1.0 STORY  
 L100 M100 B118

AREA	FLAT	EFF%	E/AREA	ACT%	A/AREA	EA/AA	HEATED
GAR	784	1.00	784	1.00	784	784	
OFF	120	1.00	120	1.00	120	120	
WD	120	1.00	120	1.00	120	120	
LIV	1568	1.00	1568	1.00	1568	1568	1568
CONDR	1224	1.00	1224	1.00	1224	1224	

MISC BLDG CODE	DESC	LENGTH	WIDTH	UNITS	ADJ PRICE	EYB DT	PCT	ADJUSTMENT	VALUE
1 1 OFF	Open Frame Porch	10.00	12.00	120.00	25.56	1999 A	13.00	1.00	2,670
2 1 WD	Wood Deck	10.00	12.00	120.00	19.35	1999 A	13.00	1.00	2,020
3 1 CONDR	Concrete Drivewa	51.00	24.00	1224.00	3.65	1996 A	16.00	1.00	3,750

LAND LUSE DESC	ZONING	UNITS TP	PRICE	ADJUSTMENT	CODE/FACTOR	VALUE
1 6200 VALMEYER	VR1	1.00 ST	26760.00	.00	.00 TW 1.00	26,760