

LOT 92 NEW VALMEYER PHASE 2

VALMEYER IL 62295  
Site Address: 000210 W HUNTERS RIDGE

BLDG # 1  
 Style/Stories 1.0 One Story  
 Quality/Design C C-Average  
 Building Use 0100 Single Fami  
 Exterior Wall F Frame  
 WALL % 100 100%  
 Exterior Wall 1  
 WALL 1% 000 N/A  
 Crawl Sp. Adj  
 Slab Adjustment  
 Basement LC C-Living Qt  
 Combination  
 Attic Area  
 Heat/AC Adj AC Central Air  
 Comb Ht/AC Adj  
 Fireplace 03 C-Fireplace  
 Extra Fireplace 00 N/A  
 Res Fixtures 0009 09 Fixtures  
 Garage F Frame Garag  
 Integral Garage  
 Remodeling Adj 01 No Remodeli  
 Actual Year Blt 1995  
 Effect Year Blt 1995  
 Cond/Desir/Util A Res CDU - A  
 Township Multpl 09 TOWNSHIP #0  
 Funct. Obs. % 000000  
 Economic Obs. % 000000  
 Observed Cond % 000000  
 Obs. Cond. Code  
 Combination A  
 Comb A Ht/AC  
 Unfin Low/Level  
 Full Basement F Full Baseme  
 # Of Bedrooms 03 Three Bedro  
 Sq.Ft.Grđ Area 1552

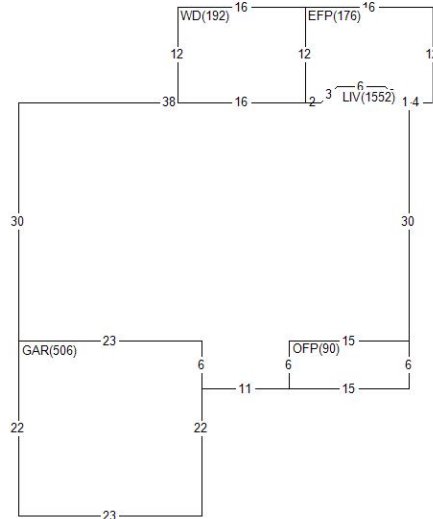

Land Value 26,760  
 Misc Value 26,950  
 Bldg Value 128,360  
 Total Value 182,070  
 Value By CAMA

RCN 154,651  
 Pct Good 0.8300  
 Obsol/Observed 0.0000  
 Building Value 128,360

DOCUMENT # DATE QS SALE PRICE  
 0994 U 6,570

PERMIT NO TYPE DATE AMOUNT  
 R1-03-14 07 0403  
 R1-01-06 05 0401  
 R1-94-16 01 0994  
 Appraiser KS K. Sondag  
 Apr Date 07/22/22  
 Use Code 0040 Imp Res  
 NBHD 62000.10 VLMYR 1.0 STORY  
 L100 M100 B118

AREA	FLAT	EFF% E/AREA	ACT% A/AREA	EA/AA HEATED
GAR	506	1.00	506 1.00	506 506
OFFP	90	1.00	90 1.00	90 90
EFFP	176	1.00	176 1.00	176 176
LIV	1552	1.00	1552 1.00	1552 1552
CONDR	782	1.00	782 1.00	782 782
BSML	168	1.00	168 1.00	168 168
WD	192	1.00	192 1.00	192 192

MISC BLDG CODE	DESC	LENGTH	WIDTH	UNITS	ADJ PRICE	EYB DT PCT	ADJUSTMENT	VALUE
1 1 OFFP	Open Frame Porch	6.00	15.00	90.00	28.19	1995 A 17.00	1.00	2,110
2 1 EFFP	Enclosed Fr. Por	.00	.00	176.00	40.53	2004 A 9.00	1.00	6,490
3 1 CONDR	Concrete Drivewa	34.00	23.00	782.00	3.65	1995 A 17.00	1.00	2,370
4 1 SHED	Frame Shed	28.00	20.00	560.00	24.95	2001 A 12.00	1.00	12,300
5 1 WD	Wood Deck	16.00	12.00	192.00	19.35	2019 A 1.00	1.00	3,680

LAND LUSE DESC	ZONING	UNITS TP	PRICE	ADJUSTMENT	CODE/FACTOR	VALUE
1 6200 VALMEYER	VR1	1.00 ST	26760.00	.00	.00 TW 1.00	26,760