

LOT 106 NEW VALMEYER PHASE 2

VALMEYER IL 62295
Site Address: 000215 W HUNTERS RIDGE

BLDG # 1
 Style/Stories 1.0 One Story
 Quality/Design C C-Average
 Building Use 0100 Single Fami
 Exterior Wall F Frame
 WALL % 100 100%
 Exterior Wall 1
 WALL 1% 000 N/A
 Crawl Sp. Adj
 Slab Adjustment
 Basement LC C-Living Qt
 Combination
 Attic Area
 Heat/AC Adj AC Central Air
 Comb Ht/AC Adj
 Fireplace 03 C-Fireplace
 Extra Fireplace 00 N/A
 Res Fixtures 0013 13 Fixtures
 Garage F Frame Garag
 Integral Garage
 Remodeling Adj 01 No Remodeli
 Actual Year Blt 1997
 Effect Year Blt 1997
 Cond/Desir/Util A Res CDU - A
 Township Multpl 09 TOWNSHIP #0
 Funct. Obs. % 000000
 Economic Obs. % 000000
 Observed Cond % 000000
 Obs. Cond. Code
 Combination A
 Comb A Ht/AC
 Unfin Low/Level
 Full Basement F Full Baseme
 # Of Bedrooms 03 Three Bedro
 Sq.Ft.Grđ Area 1918

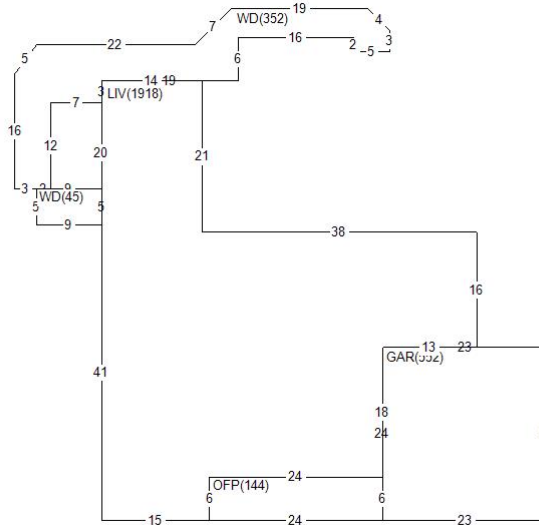

Land Value 26,760
 Misc Value 14,390
 Bldg Value 167,730
 Total Value 208,880
 Value By CAMA

RCN 197,323
 Pct Good 0.8500
 Obsol/Observed 0.0000
 Building Value 167,730

DOCUMENT #	DATE	QS	SALE PRICE
389545	0517	Q	193,000
341390	0710	U	213,000
	0397	Q	20,200

PERMIT NO	TYPE	DATE	AMOUNT
R1-05-14	10	0505	
R1-02-41	09	1203	
R1-98-12	00	1298	

Appraiser KS K. Sondag
 Apr Date 07/22/22
 Use Code 0040 Imp Res
 NBHD 62000.10 VLMYR 1.0 STORY
 L100 M100 B118

AREA	FLAT	EFF%	E/AREA	ACT%	A/AREA	EA/AA	HEATED
CONDR	600	1.00	600	1.00	600	600	
BSML	1615	1.00	1615	1.00	1615	1615	
GAR	552	1.00	552	1.00	552	552	
WD	397	1.00	397	1.00	397	397	
LIV	1918	1.00	1918	1.00	1918	1918	1918
OFFP	144	1.00	144	1.00	144	144	

MISC BLDG CODE	DESC	LENGTH	WIDTH	UNITS	ADJ PRICE	EYB DT	PCT	ADJUSTMENT	VALUE
1 1 OFFP	Open Frame Porch	6.00	24.00	144.00	24.29	1997 A	15.00	1.00	2,970
4 1 CONDR	Concrete Drivewa	30.00	20.00	600.00	3.65	1997 A	15.00	1.00	1,860
5 1 SHED	Frame Shed	12.00	12.00	144.00	26.53	1998 A	14.00	1.00	3,290
6 1 WD	Wood Deck	.00	.00	352.00	19.35	2005 A	8.00	1.00	6,270

LAND LUSE DESC	ZONING	UNITS TP	PRICE	ADJUSTMENT	CODE/FACTOR	VALUE
1 6200 VALMEYER	VR1	1.00 ST	26760.00	TW 1.00	.00 .00	26,760