

LOT 132 NEW VALMEYER PHASE 2

VALMEYER IL 62295
Site Address: 000141 W HUNTERS RIDGE

BLDG # 1
 Style/Stories 1.0 One Story
 Quality/Design C C-Average
 Building Use 0100 Single Fami
 Exterior Wall F Frame
 WALL % 100 100%
 Exterior Wall 1
 WALL 1% 000 N/A
 Crawl Sp. Adj
 Slab Adjustment
 Basement
 Combination
 Attic Area
 Heat/AC Adj AC Central Air
 Comb Ht/AC Adj
 Fireplace 03 C-Fireplace
 Extra Fireplace 00 N/A
 Res Fixtures 0008 08 Fixtures
 Garage F Frame Garag
 Integral Garage
 Remodeling Adj 01 No Remodeli
 Actual Year Blt 2003
 Effect Year Blt 2003
 Cond/Desir/Util A
 Township Multpl 09 Res CDU - A
 Funct. Obs. % TOWNSHIP #0
 Economic Obs. %
 Observed Cond %
 Obs. Cond. Code
 Combination A
 Comb A Ht/AC
 Unfin Low/Level
 Full Basement F Full Baseme
 # Of Bedrooms 03 Three Bedro
 Sq.Ft.Grnd Area 1264

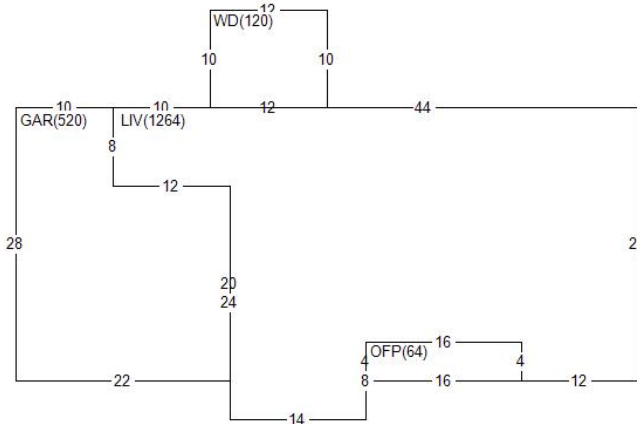

Land Value 26,760
 Misc Value 9,330
 Bldg Value 121,390
 Total Value 157,480
 Value By CAMA

RCN 134,878
 Pct Good 0.9000
 Obsol/Observed 0.0000
 Building Value 121,390

| DOCUMENT # | DATE | QS | SALE PRICE |
|------------|------|----|------------|
| 271477 | 0303 | Q | 131,900 |
| | 1002 | Q | 21,023 |

| PERMIT NO | TYPE | DATE | AMOUNT |
|-----------|------|------|--------|
| R1-02-37 | 00 | 0203 | |
| R1-02-37 | 01 | 1002 | |

Appraiser KS K. Sondag
 Appr Date 07/25/22
 Use Code 0040 Imp Res
 NBHD 62000.10 VLMYR 1.0 STORY
 L100 M100 B118

| AREA | FLAT | EFF% | E/AREA | ACT% | A/AREA | EA/AA | HEATED |
|-------|------|------|--------|------|--------|-------|--------|
| OFF | 64 | 1.00 | 64 | 1.00 | 64 | 64 | |
| GAR | 520 | 1.00 | 520 | 1.00 | 520 | 520 | |
| WD | 120 | 1.00 | 120 | 1.00 | 120 | 120 | |
| LIV | 1264 | 1.00 | 1264 | 1.00 | 1264 | 1264 | 1264 |
| CONDR | 496 | 1.00 | 496 | 1.00 | 496 | 496 | |
| PTO | 330 | 1.00 | 330 | 1.00 | 330 | 330 | |

| MISC BLDG CODE | DESC | LENGTH | WIDTH | UNITS | ADJ PRICE | EYB DT | PCT | ADJUSTMENT | VALUE |
|----------------|------------------|--------|-------|--------|-----------|--------|-------|------------|-------|
| 1 1 BRVEN | Brick Veneer | .00 | .00 | 208.00 | 14.65 | 2003 A | 10.00 | 1.00 | 2,740 |
| 2 1 OFP | Open Frame Porch | 4.00 | 16.00 | 64.00 | 31.88 | 2003 A | 10.00 | 1.00 | 1,840 |
| 3 1 WD | Wood Deck | 10.00 | 12.00 | 120.00 | 19.35 | 2003 A | 10.00 | 1.00 | 2,090 |
| 4 1 CONDR | Concrete Drivewa | 31.00 | 16.00 | 496.00 | 3.65 | 2003 F | 17.00 | 1.00 | 1,500 |
| 5 1 PTO | Concrete Patio | .00 | .00 | 330.00 | 3.65 | 2011 A | 4.00 | 1.00 | 1,160 |

| LAND LUSE DESC | ZONING | UNITS TP | PRICE | ADJUSTMENT | CODE/FACTOR | VALUE |
|-----------------|--------|----------|----------|------------|-------------|--------|
| 1 6200 VALMEYER | VR1 | 1.00 ST | 26760.00 | TW 1.00 | .00 .00 | 26,760 |