

LOT 141 NEW VALMEYER PHASE 2

VALMEYER IL 62295  
Site Address: 000108 W HUNTERS RIDGE

BLDG # 1  
 Style/Stories 1.0 One Story  
 Quality/Design C C-Average  
 Building Use 0100 Single Fami  
 Exterior Wall F Frame  
 WALL % 080 080%  
 Exterior Wall 1 M Masonry  
 WALL 1% 020 020%  
 Crawl Sp. Adj C Crawl  
 Slab Adjustment  
 Basement  
 Combination  
 Attic Area  
 Heat/AC Adj AC Central Air  
 Comb Ht/AC Adj  
 Fireplace 31 DirectVent  
 Extra Fireplace 00 N/A  
 Res Fixtures 0008 08 Fixtures  
 Garage F Frame Garag  
 Integral Garage  
 Remodeling Adj 01 No Remodeli  
 Actual Year Blt 2002  
 Effect Year Blt 2002  
 Cond/Desir/Util A Res CDU - A  
 Township Multpl 09 TOWNSHIP #0  
 Funct. Obs. %  
 Economic Obs. %  
 Observed Cond %  
 Obs. Cond. Code  
 Combination A  
 Comb A Ht/AC  
 Unfin Low/Level  
 Full Basement  
 # Of Bedrooms 03 Three Bedro  
 Sq.Ft.Grd Area 1456

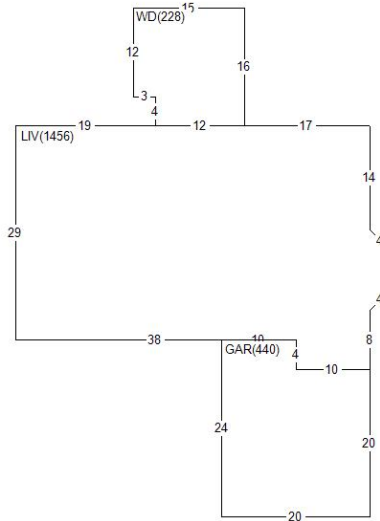

Land Value 26,760  
 Misc Value 7,410  
 Bldg Value 128,000  
 Total Value 162,170  
 Value By CAMA

RCN 143,817  
 Pct Good 0.8900  
 Obsol/Observed 0.0000  
 Building Value 128,000

DOCUMENT #	DATE	QS	SALE PRICE
419769	0921	U	
408228	0520	Q	152,000
365990	0713	Q	121,600

PERMIT NO	TYPE	DATE	AMOUNT
R1-05-22	10	0705	
R1-02-02	00	0702	
R1-02-26	08	0802	

Appraiser KS K. Sondag  
 Appr Date 07/25/22  
 Use Code 0040 Imp Res  
 NBHD 62000.10 VLMYR 1.0 STORY  
 L100 M100 B118

AREA	FLAT	EFF%	E/AREA	ACT%	A/AREA	EA/AA	HEATED
GAR	440	1.00	440	1.00	440	440	
LIV	1456	1.00	1456	1.00	1456	1456	1456
CRWL	64	1.00	64	1.00	64	64	
CONDR	522	1.00	522	1.00	522	522	
WD	228	1.00	228	1.00	228	228	

MISC BLDG CODE	DESC	LENGTH	WIDTH	UNITS	ADJ PRICE	EYB DT	PCT	ADJUSTMENT	VALUE
1 1 PTO	Concrete Patio	10.00	10.00	100.00	3.65	2002 A	11.00	1.00	330
2 1 CONDR	Concrete Drivewa	29.00	18.00	522.00	3.65	2002 A	11.00	1.00	1,700
3 1 BRVEN	Brick Veneer	.00	.00	81.00	14.65	2002 A	11.00	1.00	1,060
4 1 WD	Wood Deck	.00	.00	228.00	19.35	2015 A	2.00	1.00	4,320

LAND LUSE DESC	ZONING	UNITS TP	PRICE	ADJUSTMENT	CODE/FACTOR	VALUE
1 6200 VALMEYER	VR1	1.00 ST	26760.00	TW 1.00	.00 .00	26,760