

LOT 150 NEW VALMEYER PHASE 2

VALMEYER IL 62295
Site Address: 000125 W HUNTERS RIDGE

BLDG # 1
 Style/Stories 1.0 One Story
 Quality/Design C C-Average
 Building Use 0100 Single Fami
 Exterior Wall F Frame
 WALL % 100 100%
 Exterior Wall 1
 WALL 1% 000 N/A
 Crawl Sp. Adj
 Slab Adjustment
 Basement
 Combination
 Attic Area
 Heat/AC Adj AC Central Air
 Comb Ht/AC Adj
 Fireplace 00 N/A
 Extra Fireplace 00 N/A
 Res Fixtures 0008 08 Fixtures
 Garage F Frame Garag
 Integral Garage
 Remodeling Adj 01 No Remodeli
 Actual Year Blt 2003
 Effect Year Blt 2003
 Cond/Desir/Util A Res CDU - A
 Township Multpl 09 TOWNSHIP #0
 Funct. Obs. %
 Economic Obs. %
 Observed Cond %
 Obs. Cond. Code
 Combination A
 Comb A Ht/AC
 Unfin Low/Level
 Full Basement F Full Baseme
 # Of Bedrooms 03 Three Bedro
 Sq.Ft.Grd Area 1410

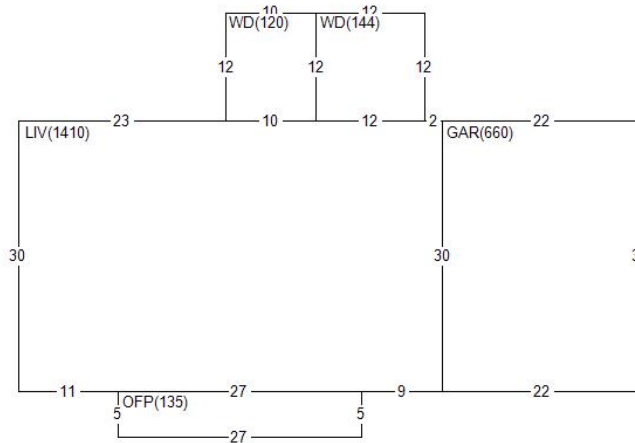

Land Value 26,760
 Misc Value 9,800
 Bldg Value 126,640
 Total Value 163,200
 Value By CAMA

RCN 140,714
 Pct Good 0.9000
 Obsol/Observed 0.0000
 Building Value 126,640

DOCUMENT #	DATE	QS	SALE PRICE
370947	0514	Q	135,000
273285	0403	Q	18,220

PERMIT NO	TYPE	DATE	AMOUNT
R1-08-07	10	0608	
R1-03-24	01	0603	

Appraiser KS K. Sondag
 Appr Date 07/25/22
 Use Code 0040 Imp Res
 NBHD 62000.10 VLMYR 1.0 STORY
 L100 M100 B118

AREA	FLAT	EFF%	E/AREA	ACT%	A/AREA	EA/AA	HEATED
CONDR	527	1.00	527	1.00	527	527	
PTO	253	1.00	253	1.00	253	253	
WD	264	1.00	264	1.00	264	264	
OFFP	135	1.00	135	1.00	135	135	
GAR	660	1.00	660	1.00	660	660	
LIV	1410	1.00	1410	1.00	1410	1410	1410

MISC BLDG CODE	DESC	LENGTH	WIDTH	UNITS	ADJ PRICE	EYB DT PCT	ADJUSTMENT	VALUE
1	1 OFFP	Open Frame Porch	5.00	27.00	135.00	24.72 2003 A 10.00	1.00	3,000
2	1 WD	Wood Deck	12.00	10.00	120.00	19.35 2003 F 17.00	1.00	1,930
3	1 PTO	Concrete Patio	11.00	11.00	121.00	3.65 2003 A 10.00	1.00	400
4	1 CONDR	Concrete Drivewa	31.00	17.00	527.00	3.65 2003 F 17.00	1.00	1,600
5	1 WD	Wood Deck	12.00	12.00	144.00	19.35 2008 F 13.00	1.00	2,420
6	1 PTO	Concrete Patio	11.00	12.00	132.00	3.65 2008 A 6.00	1.00	450
LAND LUSE DESC	ZONING	UNITS TP	PRICE	ADJUSTMENT	CODE/FACTOR	ADJUSTMENT	VALUE	
1 6200 VALMEYER	VR1	1.00 ST	26760.00	.00	.00	.00 TW 1.00	26,760	