

LOT 8 NEW VALMEYER PHASE 1

WATERLOO IL 62298

Site Address: 000230 E HARRISONVILLE DR

BLDG # 1
 Style/Stories MH Mobil Home
 Quality/Design C C-Average
 Building Use 0200 Mob. Home S
 Exterior Wall MH Mobile Home
 WALL % 100 100%
 Exterior Wall 1
 WALL 1% 000 N/A
 Crawl Sp. Adj BP Conc/Blk Pe
 Slab Adjustment
 Basement
 Combination
 Attic Area
 Heat/AC Adj AC Central Air
 Comb Ht/AC Adj
 Fireplace 00 N/A
 Extra Fireplace 00 N/A
 Res Fixtures 0005 05 Fixtures
 Garage
 Integral Garage
 Remodeling Adj 01 No Remodeli
 Actual Year Blt 1993
 Effect Year Blt 1993
 Cond/Desir/Util MH Mobile Home
 Township Multpl 09 TOWNSHIP #0
 Funct. Obs. % 000000
 Economic Obs. % 000000
 Observed Cond % 000000
 Obs. Cond. Code
 Combination A
 Comb A Ht/AC
 Unfin Low/Level
 Full Basement
 # Of Bedrooms 02 Two Bedroom
 Sq.Ft.Gr'd Area 924

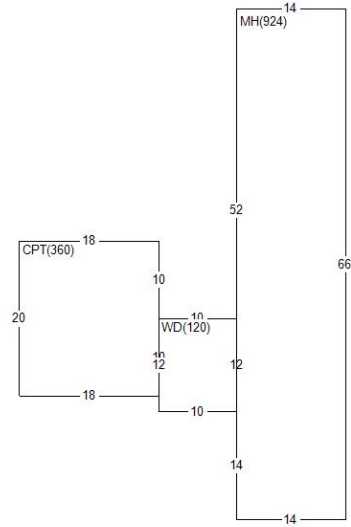

Land Value 26,760
 Misc Value 5,750
 Bldg Value 21,560
 Total Value 54,070
 Value By CAMA

RCN 61,596
 Pct Good 0.3500
 Obsol/Observed 0.0000
 Building Value 21,560

DOCUMENT #	DATE	QS	SALE PRICE
346615	0111	U	40,000
	0102	Q	40,000
	0894	U	3,450

PERMIT NO	TYPE	DATE	AMOUNT
R3-05-02	05	0505	
R3-95-07	11	0895	

Appraiser KS K. Sondag
 Appr Date 07/25/22
 Use Code 0040 Imp Res
 NBHD 62000.40 VLMYR MOBILE HOME
 L100 M100 B127

AREA	FLAT	EFF%	E/AREA	ACT%	A/AREA	EA/AA	HEATED
CPT	360	1.00	360	1.00	360	360	
WD	204	1.00	204	1.00	204	204	
MH	924	1.00	924	1.00	924	924	924
SHED	130	1.00	130	1.00	130	130	

MISC BLDG CODE	DESC	LENGTH	WIDTH	UNITS	ADJ PRICE	EYB DT PCT	ADJUSTMENT	VALUE
1 1 WD	Wood Deck	12.00	10.00	120.00	15.87	1995 MH 65.00	.82	670
2 1 SALV	Salvage Structur	.00	.00	1.00	300.00	1995 OD 0.00	1.00	300
3 1 CPTMTL	Carpport Metal	20.00	18.00	360.00	3.58	2005 A 8.00	1.00	1,190
4 1 WD	Wood Deck	7.00	12.00	84.00	19.35	2003 A 10.00	1.00	1,460
5 1 ASP	Asphalt Driveway	.00	.00	804.00	2.85	2007 A 7.00	1.00	2,130

LAND LUSE DESC	ZONING	UNITS TP	PRICE	ADJUSTMENT	CODE/FACTOR	VALUE
1 6200 VALMEYER	VR3	1.00 ST	26760.00	.00	.00 TW 1.00	26,760