

Req By: KRIS_K
 WM LOWELL NABERS &
 KEITH & TODD NABERS
 214 WEST WOODLAND RIDGE

LOT 169 NEW VALMEYER PHASE 3

VALMEYER IL 62295
 Site Address: 000214 W WOODLAND RIDGE

BLDG # 1
 Style/Stories 1.0 One Story
 Quality/Design C C-Average
 Building Use 0100 Single Fami
 Exterior Wall M Masonry 1.0
 WALL % 100 100%
 Exterior Wall 1
 WALL 1% 000 N/A
 Crawl Sp. Adj C Crawl
 Slab Adjustment
 Basement
 Combination
 Attic Area
 Heat/AC Adj AC Central Air
 Comb Ht/AC Adj
 Fireplace
 Extra Fireplace 00 N/A
 Res Fixtures 0009 09 Fixtures
 Garage M Masonry Gar
 Integral Garage
 Remodeling Adj 01 No Remodeli
 Actual Year Blt 1995
 Effect Year Blt 1995
 Cond/Desir/Util A Res CDU - A
 Township Multpl 09 TOWNSHIP #0
 Funct. Obs. % 000000
 Economic Obs. % 000000
 Observed Cond % 000000
 Obs. Cond. Code
 Combination A
 Comb A Ht/AC
 Unfin Low/Level
 Full Basement F Full Baseme
 # Of Bedrooms 03 Three Bedro
 Sq.Ft.Grđ Area 2324

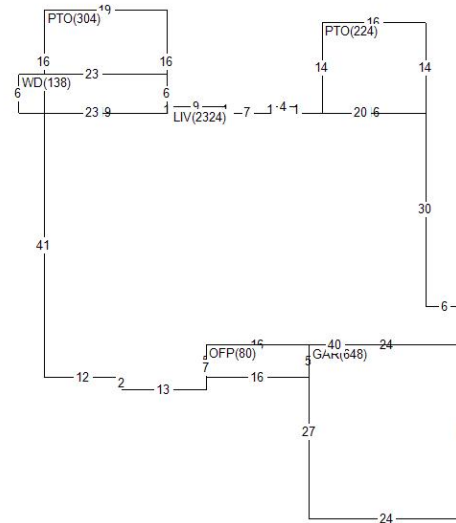

Land Value 26,760
 Misc Value 9,140
 Bldg Value 217,780
 Total Value 253,680
 Value By CAMA

RCN 265,589
 Pct Good 0.8200
 Obsol/Observed 0.0000
 Building Value 217,780

DOCUMENT #	DATE	QS	SALE PRICE
387702	0117	U	
	1094	U	13,103

PERMIT NO	TYPE	DATE	AMOUNT
R1-95-22	01	0795	

Appraiser KS K. Sondag
 Apr Date 07/20/22
 Use Code 0040 Imp Res
 NBHD 62000.10 VLMYR 1.0 STORY
 L100 M100 B144

AREA	FLAT	EFF%	E/AREA	ACT%	A/AREA	EA/AA	HEATED
CRWL	13	1.00	13	1.00	13	13	
CONDR	1221	1.00	1221	1.00	1221	1221	
OFFP	80	1.00	80	1.00	80	80	
GAR	648	1.00	648	1.00	648	648	
PTO	528	1.00	528	1.00	528	528	
LIV	2324	1.00	2324	1.00	2324	2324	2324
WD	138	1.00	138	1.00	138	138	

MISC BLDG CODE	DESC	LENGTH	WIDTH	UNITS	ADJ PRICE	EYB DT PCT	ADJUSTMENT	VALUE
1	1 OFFP	5.00	16.00	80.00	29.38	1995 A 18.00	1.00	1,930
2	1 PTO	16.00	19.00	304.00	3.65	1995 A 18.00	1.00	910
3	1 CONDR	.00	.00	1221.00	3.65	1995 F 26.00	1.00	3,300
4	1 WD	6.00	23.00	138.00	19.35	1999 A 14.00	1.00	2,300
5	1 PTO	14.00	16.00	224.00	3.65	1999 A 14.00	1.00	700

LAND LUSE DESC	ZONING	UNITS TP	PRICE	ADJUSTMENT	CODE/FACTOR	VALUE
1 6200 VALMEYER	VR1	1.00 ST	26760.00	.00	.00 TW 1.00	26,760