

LOT 158 NEW VALMEYER PHASE 3

VALMEYER IL 62295
Site Address: 000128 W WOODLAND RIDGE

BLDG # 1
 Style/Stories 1.0 One Story
 Quality/Design C C-Average
 Building Use 0100 Single Fami
 Exterior Wall F Frame
 WALL % 100 100%
 Exterior Wall 1
 WALL 1% 000 N/A
 Crawl Sp. Adj
 Slab Adjustment
 Basement
 Combination
 Attic Area
 Heat/AC Adj AC Central Air
 Comb Ht/AC Adj
 Fireplace 31 DirectVent
 Extra Fireplace 00 N/A
 Res Fixtures 0007 07 Fixtures
 Garage F Frame Garag
 Integral Garage
 Remodeling Adj 01 No Remodeli
 Actual Year Blt 1995
 Effect Year Blt 1995
 Cond/Desir/Util A Res CDU - A
 Township Multpl 09 TOWNSHIP #0
 Funct. Obs. % 000000
 Economic Obs. % 000000
 Observed Cond % 000000
 Obs. Cond. Code
 Combination A
 Comb A Ht/AC
 Unfin Low/Level
 Full Basement F Full Baseme
 # Of Bedrooms 02 Two Bedroom
 Sq.Ft.Grnd Area 1840

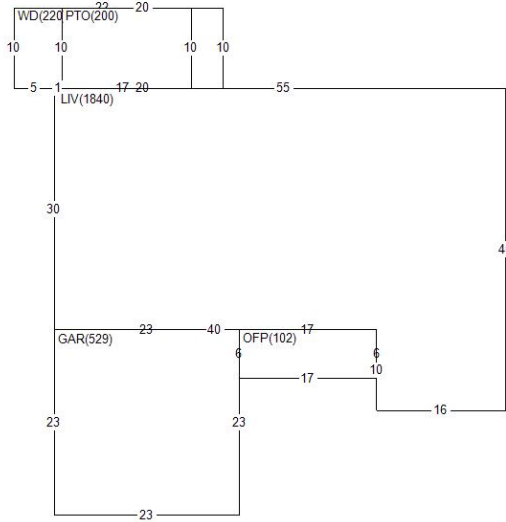

Land Value 26,760
 Misc Value 10,990
 Bldg Value 192,120
 Total Value 229,870
 Value By CAMA

RCN 237,188
 Pct Good 0.8100
 Obsol/Observed 0.0000
 Building Value 192,120

DOCUMENT #	DATE	QS	SALE PRICE
419303	0821	U	
351118	1011	Q	165,000
	0601	04	

PERMIT NO	TYPE	DATE	AMOUNT
R1-95-17	01	0795	

Appraiser KS K. Sondag
 Apr Date 07/20/22
 Use Code 0040 Imp Res
 NBHD 62000.10 VLMYR 1.0 STORY
 L100 M100 B169

AREA	FLAT	EFF%	E/AREA	ACT%	A/AREA	EA/AA	HEATED
OFFP	102	1.00	102	1.00	102	102	
GAR	529	1.00	529	1.00	529	529	
WD	220	1.00	220	1.00	220	220	
PTO	200	1.00	200	1.00	200	200	
LIV	1840	1.00	1840	1.00	1840	1840	1840
CONDR	1600	1.00	1600	1.00	1600	1600	

MISC BLDG CODE	DESC	LENGTH	WIDTH	UNITS	ADJ PRICE	EYB DT PCT	ADJUSTMENT	VALUE
1	1 OFP	Open Frame Porch	6.00	17.00	102.00	26.86 1995 A 19.00	1.00	2,220
2	1 WD	Wood Deck	10.00	22.00	220.00	19.35 1995 A 19.00	1.00	3,450
3	1 PTO	Concrete Patio	10.00	20.00	200.00	3.65 1995 A 19.00	1.00	590
4	1 CONDR	Concrete Drivewa	.00	.00	1600.00	3.65 1995 A 19.00	1.00	4,730

LAND LUSE DESC	ZONING	UNITS TP	PRICE	ADJUSTMENT	CODE/FACTOR	VALUE
1 6200 VALMEYER	VR1	1.00 ST	26760.00	.00	.00 TW 1.00	26,760