

Req By: DAWN
HERCULES D KARAKATSANIS
MARIA J KARAKATSANIS
215 W HARRISONVILLE DR

LOT 129 NEW VALMEYER PHASE 2

VALMEYER IL 62295

Site Address: 000215 W HARRISONVILLE DR

BLDG # 1
 Style/Stories 1.0 One Story
 Quality/Design C C-Average
 Building Use 0100 Single Fami
 Exterior Wall F Frame
 WALL % 100 100%
 Exterior Wall 1
 WALL 1% 000 N/A
 Crawl Sp. Adj
 Slab Adjustment
 Basement
 Combination
 Attic Area
 Heat/AC Adj AC Central Air
 Comb Ht/AC Adj
 Fireplace DirectVent
 Extra Fireplace 00 N/A
 Res Fixtures 0010 10 Fixtures
 Garage F Frame Garag
 Integral Garage
 Remodeling Adj 01 No Remodeli
 Actual Year Blt 2004
 Effect Year Blt 2004
 Cond/Desir/Util A Res CDU - A
 Township Multpl 09 TOWNSHIP #0
 Funct. Obs. %
 Economic Obs. %
 Observed Cond %
 Obs. Cond. Code
 Combination A
 Comb A Ht/AC
 Unfin Low/Level
 Full Basement F Full Baseme
 # Of Bedrooms 03 Three Bedro
 Sq.Ft.Grđ Area 1544

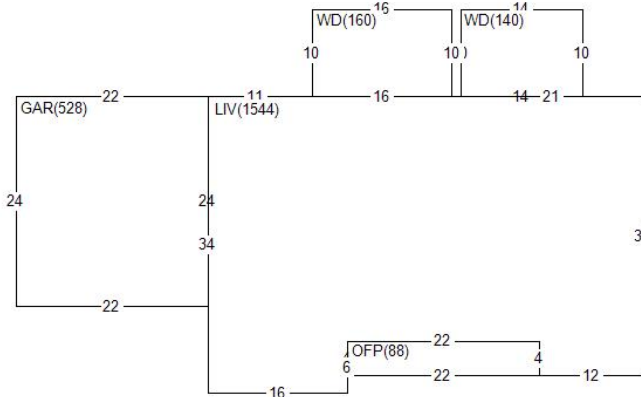

Land Value 26,760
 Misc Value 16,020
 Bldg Value 196,350
 Total Value 239,130
 Value By CAMA

RCN 220,619
 Pct Good 0.8900
 Obsol/Observed 0.0000
 Building Value 196,350

DOCUMENT #	DATE	QS	SALE PRICE
363225	0313	Q	137,000
350746	0911	U	
349930	0811	U	
PERMIT NO	TYPE	DATE	AMOUNT
R1-04-16	01	0404	

Appraiser KS K. Sondag
 Appr Date 07/21/22
 Use Code 0040 Imp Res
 NBHD 62000.10 VLMYR 1.0 STORY
 L100 M100 B169

AREA	FLAT	EFF% E/AREA	ACT% A/AREA	EA/AA HEATED
CONDR	792	1.00	792 1.00	792 792
OFP	88	1.00	88 1.00	88 88
GAR	528	1.00	528 1.00	528 528
WD	300	1.00	300 1.00	300 300
LIV	1544	1.00	1544 1.00	1544 1544

MISC BLDG CODE	DESC	LENGTH	WIDTH	UNITS	ADJ PRICE	EYB DT PCT	ADJUSTMENT	VALUE
1 1 BRVEN	Brick Veneer	.00	.00	464.00	14.65	2004 A 11.00	1.00	6,050
2 1 OFP	Open Frame Porch	4.00	22.00	88.00	28.43	2004 A 11.00	1.00	2,230
3 1 WD	Wood Deck	10.00	16.00	160.00	19.35	2004 A 11.00	1.00	2,760
4 1 WD	Wood Deck	10.00	14.00	140.00	19.35	2004 A 11.00	1.00	2,410
5 1 CONDR	Concrete Drivewa	44.00	18.00	792.00	3.65	2004 A 11.00	1.00	2,570

LAND LUSE DESC	ZONING	UNITS TP	PRICE	ADJUSTMENT	CODE/FACTOR	VALUE
1 6200 VALMEYER	VR1	1.00 ST	26760.00	TW 1.00	.00 .00	26,760