

Req By: DAWN
DINA M LIVINGSTON
ROY L OTTEN
111 SOUTH CEDAR BLUFF DRIVE

UNIT 5 OF COTTAGE HILLS
CONDOMINIUMS PLAT 1

VALMEYER IL 62295

Site Address: 000111 S CEDAR BLUFF DR

BLDG # 1
 Style/Stories 2.0 2 Story
 Quality/Design C C-Average
 Building Use 0100 Single Fami
 Exterior Wall F Frame 2.0
 WALL % 100 100%
 Exterior Wall 1
 WALL 1% 000 N/A
 Crawl Sp. Adj
 Slab Adjustment S Slab
 Basement
 Combination
 Attic Area
 Heat/AC Adj AC Central Air
 Comb Ht/AC Adj
 Fireplace 00 N/A
 Extra Fireplace 00 N/A
 Res Fixtures 0010 10 Fixtures
 Garage F Frame Garag
 Integral Garage IG Integral Ga
 Remodeling Adj 01 No Remodeli
 Actual Year Blt 2006
 Effect Year Blt 2006
 Cond/Desir/Util A Res CDU - A
 Township Multpl 09 TOWNSHIP #0
 Funct. Obs. %
 Economic Obs. %
 Observed Cond %
 Obs. Cond. Code
 Combination A
 Comb A Ht/AC
 Unfin Low/Level
 Full Basement
 # Of Bedrooms 03 Three Bedro
 Sq.Ft.Grđ Area 1000

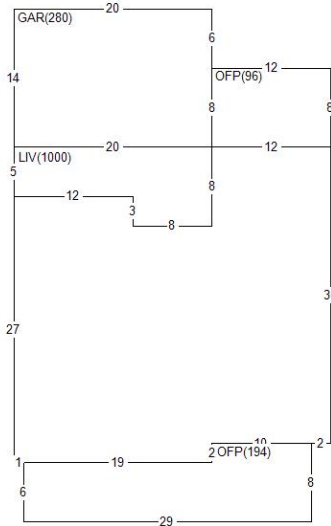

Land Value 13,380
 Misc Value 8,700
 Bldg Value 149,830
 Total Value 171,910
 Value By CAMA

RCN 164,643
 Pct Good 0.9100
 Obsol/Observed 0.0000
 Building Value 149,830

| DOCUMENT # | DATE | QS | SALE PRICE |
|------------|------|------|------------|
| 373340 | 1014 | Q | 120,000 |
| 364504 | 0413 | U | |
| 317365 | 0807 | U | 159,000 |
| PERMIT NO | TYPE | DATE | AMOUNT |
| R4-06-01 | 01 | 0606 | |

Appraiser KS K. Sondag
 Appr Date 07/21/22
 Use Code 1040 Condominium
 NBHD 62000.35 VLMYR CONDO
 L100 M100 B139

| AREA | FLAT | EFF% E/AREA | ACT% A/AREA | EA/AA HEATED |
|-------|------|-------------|-------------|--------------|
| CONDR | 432 | 1.00 | 432 | 432 |
| SLAB | 1000 | 1.00 | 1000 | 1000 |
| IG | 124 | 1.00 | 124 | 124 |
| OFFP | 290 | 1.00 | 290 | 290 |
| GAR | 280 | 1.00 | 280 | 280 |
| LIV | 1000 | 1.00 | 1000 | 1000 |

| MISC BLDG CODE | DESC | LENGTH | WIDTH | UNITS | ADJ PRICE | EYB DT PCT | ADJUSTMENT | VALUE |
|----------------|---------|------------------|-------|-------|-----------|-------------------|------------|-------|
| 1 | 1 OFFP | Open Frame Porch | .00 | .00 | 194.00 | 22.91 2006 A 9.00 | 1.00 | 4,050 |
| 2 | 1 OFFP | Open Frame Porch | 8.00 | 12.00 | 96.00 | 27.48 2006 A 9.00 | 1.00 | 2,400 |
| 3 | 1 CONDR | Concrete Drivewa | 24.00 | 18.00 | 432.00 | 3.65 2006 A 9.00 | 1.00 | 1,440 |
| 4 | 1 CONDR | Concrete Drivewa | 24.00 | 10.00 | 240.00 | 3.65 2007 A 8.00 | 1.00 | 810 |

| LAND LUSE DESC | ZONING | UNITS TP | PRICE | ADJUSTMENT | CODE/FACTOR | VALUE |
|-----------------|--------|----------|----------|----------------|-------------|--------|
| 1 6200 VALMEYER | VR4 | 1.00 ST | 26760.00 | TW 1.00 CN .50 | .00 | 13,380 |