

LOT 86 NEW VALMEYER PHASE 2

VALMEYER IL 62295

Site Address: 000100 W HARRISONVILLE DR

BLDG # 1  
 Style/Stories 1.0 One Story  
 Quality/Design C C-Average  
 Building Use 0100 Single Fami  
 Exterior Wall F Frame  
 WALL % 100 100%  
 Exterior Wall 1  
 WALL 1% 000 N/A  
 Crawl Sp. Adj  
 Slab Adjustment  
 Basement  
 Combination  
 Attic Area  
 Heat/AC Adj AC Central Air  
 Comb Ht/AC Adj  
 Fireplace 00 N/A  
 Extra Fireplace 00 N/A  
 Res Fixtures 0008 08 Fixtures  
 Garage F Frame Garag  
 Integral Garage  
 Remodeling Adj 01 No Remodeli  
 Actual Year Blt 1999  
 Effect Year Blt 1999  
 Cond/Desir/Util A Res CDU - A  
 Township Multpl 09 TOWNSHIP #0  
 Funct. Obs. % 000000  
 Economic Obs. % 000000  
 Observed Cond % 000000  
 Obs. Cond. Code  
 Combination A  
 Comb A Ht/AC  
 Unfin Low/Level  
 Full Basement F Full Baseme  
 # Of Bedrooms 03 Three Bedro  
 Sq.Ft.Grd Area 1300

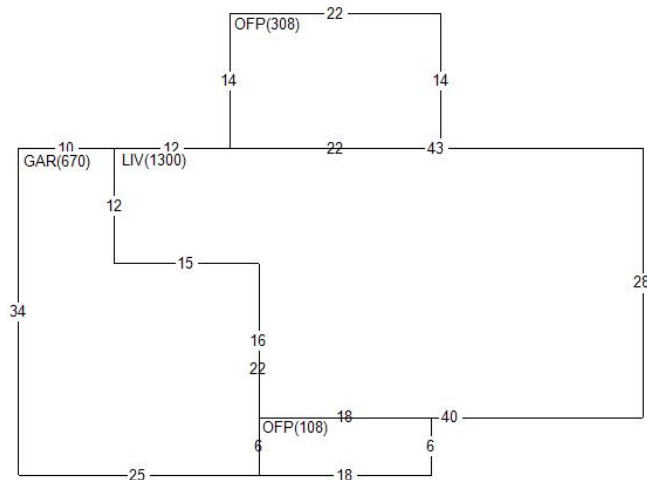

Land Value 26,760  
 Misc Value 15,660  
 Bldg Value 163,830  
 Total Value 206,250  
 Value By CAMA

RCN 192,746  
 Pct Good 0.8500  
 Obsol/Observed 0.0000  
 Building Value 163,830

DOCUMENT # DATE QS SALE PRICE  
 0898 Q 17,000

PERMIT NO TYPE DATE AMOUNT  
 R1-11-05 07 1011  
 R1-06-04 08 0306  
 R1-99-05 01 0599  
 Appraiser KS K. Sondag  
 Appr Date 07/22/22  
 Use Code 0040 Imp Res  
 NBHD 62000.10 VLMYR 1.0 STORY  
 L100 M100 B169

AREA	FLAT	EFF%	E/AREA	ACT%	A/AREA	EA/AA	HEATED
OFF	416	1.00	416	1.00	416	416	
GAR	670	1.00	670	1.00	670	670	
LIV	1300	1.00	1300	1.00	1300	1300	1300
CONDR	1184	1.00	1184	1.00	1184	1184	

MISC BLDG CODE	DESC	LENGTH	WIDTH	UNITS	ADJ PRICE	EYB DT PCT	ADJUSTMENT	VALUE
1 1 CONDR	Concrete Drivewa	37.00	32.00	1184.00	3.65	1999 A 15.00	1.00	3,670
2 1 OFP	Open Frame Porch	6.00	18.00	108.00	26.42	1999 A 15.00	1.00	2,430
3 1 BRVEN	Brick Veneer	76.00	3.00	228.00	14.65	1999 A 15.00	1.00	2,840
4 1 OFP	Open Frame Porch	14.00	22.00	308.00	22.74	2013 A 4.00	1.00	6,720

LAND LUSE DESC	ZONING	UNITS TP	PRICE	ADJUSTMENT	CODE/FACTOR	VALUE
1 6200 VALMEYER	VR1	1.00 ST	26760.00	TW 1.00	.00 .00	26,760