

LOT 142 NEW VALMEYER PHASE 2

VALMEYER IL 62295
Site Address: 000112 W HUNTERS RIDGE

BLDG # 1
 Style/Stories 1.0 One Story
 Quality/Design C C-Average
 Building Use 0100 Single Fami
 Exterior Wall F Frame
 WALL % 100 100%
 Exterior Wall 1
 WALL 1% 000 N/A
 Crawl Sp. Adj
 Slab Adjustment
 Basement
 Combination
 Attic Area
 Heat/AC Adj AC Central Air
 Comb Ht/AC Adj
 Fireplace 03 C-Fireplace
 Extra Fireplace 00 N/A
 Res Fixtures 0008 08 Fixtures
 Garage F Frame Garag
 Integral Garage
 Remodeling Adj 01 No Remodeli
 Actual Year Blt 1995
 Effect Year Blt 1995
 Cond/Desir/Util A Res CDU - A
 Township Multpl 09 TOWNSHIP #0
 Funct. Obs. % 000000
 Economic Obs. % 000000
 Observed Cond % 000000
 Obs. Cond. Code
 Combination A
 Comb A Ht/AC
 Unfin Low/Level
 Full Basement F Full Baseme
 # Of Bedrooms 03 Three Bedro
 Sq.Ft.Grd Area 1344

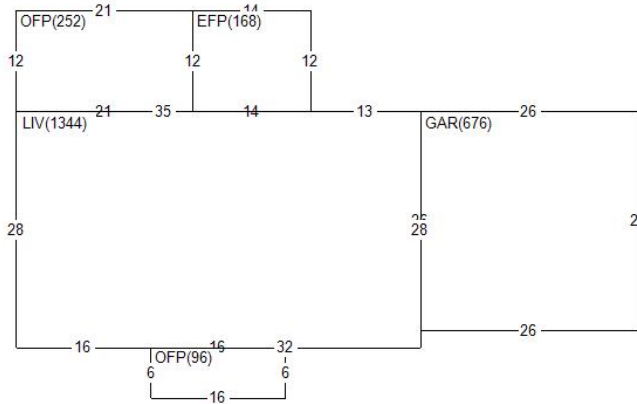

Land Value 26,760
 Misc Value 32,250
 Bldg Value 165,830
 Total Value 224,840
 Value By CAMA

RCN 204,732
 Pct Good 0.8100
 Obsol/Observed 0.0000
 Building Value 165,830

DOCUMENT # DATE QS SALE PRICE
 0994 U 5,400

PERMIT NO TYPE DATE AMOUNT
 R1-02-11 05 0402
 R1-94-27 01 1094

Appraiser KS K. Sondag
 Appr Date 07/25/22
 Use Code 0040 Imp Res
 NBHD 62000.10 VLMYR 1.0 STORY
 L100 M100 B169

AREA	FLAT	EFF%	E/AREA	ACT%	A/AREA	EA/AA	HEATED
SHED	64	1.00	64	1.00	64	64	
CONDR	1449	1.00	1449	1.00	1449	1449	
OFF	348	1.00	348	1.00	348	348	
GAR	676	1.00	676	1.00	676	676	
EFP	168	1.00	168	1.00	168	168	
LIV	1344	1.00	1344	1.00	1344	1344	1344

MISC BLDG CODE	DESC	LENGTH	WIDTH	UNITS	ADJ PRICE	EYB DT PCT	ADJUSTMENT	VALUE
1 1 OFF	Open Frame Porch	6.00	16.00	96.00	27.48	1995 A 19.00	1.00	2,140
2 1 EFP	Enclosed Fr. Por	12.00	14.00	168.00	40.88	2007 A 8.00	1.00	6,320
3 1 GARF	Garage Frame	24.00	32.00	768.00	19.22	1995 A 19.00	1.00	11,960
4 1 SHED	Frame Shed	8.00	8.00	64.00	26.79	2001 A 13.00	1.00	1,490
5 1 CONDR	Concrete Drivewa	31.00	18.00	558.00	3.65	2002 A 12.00	1.00	1,790
6 1 CONDR	Concrete Drivewa	.00	.00	891.00	3.65	2002 A 12.00	1.00	2,860
LAND LUSE DESC	ZONING	UNITS TP	PRICE	ADJUSTMENT	CODE/FACTOR	ADJUSTMENT	VALUE	
1 6200 VALMEYER	VR1	1.00 ST	26760.00	.00	.00	.00 TW 1.00	26,760	

MISC BLDG CODE	DESC	Site Address:	VALMEYER	IL 62295	HUNTERS RIDGE	LENGTH	WIDTH	UNITS	ADJ PRICE	EYB DT	PCT	ADJUSTMENT	VALUE
7 1 OFP	Open Frame Porch	000112 W				12.00	21.00	252.00	23.76	2011 A	5.00	1.00	5,690