

PART LOT 2 PART N2 NW4

RED BUD IL 62278
Site Address: 001500 AMES RD

BLDG # 1
 Style/Stories 2.0 2 Story
 Quality/Design C C-Average
 Building Use 0100 Single Fami
 Exterior Wall F Frame 2.0
 WALL % 100 100%
 Exterior Wall 1
 WALL 1% 000 N/A
 Crawl Sp. Adj C Crawl
 Slab Adjustment
 Basement
 Combination F1 Frame/1.0
 Attic Area
 Heat/AC Adj NH No Heat
 Comb Ht/AC Adj
 Fireplace 00 N/A
 Extra Fireplace 00 N/A
 Res Fixtures 0005 05 Fixtures
 Garage
 Integral Garage
 Remodeling Adj 02 Slight Upda
 Actual Year Blt 1870
 Effect Year Blt 1870
 Cond/Desir/Util F Res CDU - F
 Township Multpl 18 TOWNSHIP #1
 Funct. Obs. % 000000
 Economic Obs. % 000000
 Observed Cond % 000000
 Obs. Cond. Code
 Combination A
 Comb A Ht/AC
 Unfin Low/Level
 Full Basement
 # Of Bedrooms 02 Two Bedroom
 Sq.Ft.Grd Area 981

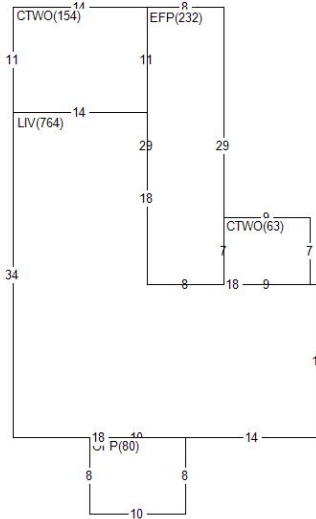

Land Value 28,630
 Misc Value 26,410
 Bldg Value 67,770
 Total Value 122,810
 Value By CAMA

RCN 144,195
 Pct Good 0.4700
 Obsol/Observed 0.0000
 Building Value 67,770

| DOCUMENT # | DATE | QS | SALE PRICE |
|------------|------|----|------------|
| 431966 | 0224 | U | |
| 428163 | 0323 | U | |
| | 1085 | U | 36,500 |

| PERMIT NO | TYPE | DATE | AMOUNT |
|-----------|------|------|--------|
| | | | |

Appraiser AS A. Schwar
 Appr Date 03/04/24
 Use Code 0011 Imp. Farm
 NBHD 1800.61 A-18 2.0 PR/1940
 L100 M100 B143

| AREA | FLAT | EFF% | E/AREA | ACT% | A/AREA | EA/AA | HEATED |
|------|------|------|--------|------|--------|-------|--------|
| CRWL | 981 | 1.00 | 981 | 1.00 | 981 | 981 | |
| OFP | 80 | 1.00 | 80 | 1.00 | 80 | 80 | |
| CTWO | 217 | 1.00 | 217 | 1.00 | 217 | 217 | |
| EFP | 232 | 1.00 | 232 | 1.00 | 232 | 232 | |
| LIV | 764 | 1.00 | 764 | 1.00 | 764 | 764 | 764 |

| MISC BLDG CODE | DESC | LENGTH | WIDTH | UNITS | ADJ PRICE | EYB DT PCT | ADJUSTMENT | VALUE |
|----------------|------------------|--------|-------|--------|-----------|---------------|------------|-------|
| 1 1 UH | Unit Heaters | .00 | .00 | 2.00 | 1135.00 | 00 OD 0.00 | 1.00 | 2,270 |
| 2 1 OFP | Open Frame Porch | 8.00 | 10.00 | 80.00 | 29.38 | 1870 P 60.00 | 1.00 | 940 |
| 3 1 EFP | Enclosed Fr. Por | 8.00 | 29.00 | 232.00 | 38.80 | 1930 P 60.00 | 1.00 | 3,600 |
| 4 1 F-SALV | Salv Farm Buildi | .00 | .00 | 1.00 | 300.00 | 00 FD 0.00 | 1.00 | 300 |
| 5 2 F-FRSHE08 | Frame Shed 8' | .00 | .00 | 992.00 | 22.14 | 1901 F3 85.00 | 1.00 | 3,290 |
| 6 3 F-SB01818 | Stl Gr Bin D18 H | .00 | .00 | 1.00 | 8175.00 | 1971 F7 85.00 | .75 | 1,230 |

| LAND LUSE DESC | ZONING | UNITS TP | PRICE | ADJUSTMENT | CODE/FACTOR | VALUE |
|-----------------------|--------|----------|----------|------------|-------------|--------|
| 1 CD County Road Cat. | MAL | 2.50 R | 11453.33 | .00 | .00 TW 1.00 | 28,630 |

Req By: DAWN
 DWIGHT A JACOBS TRUST
 4485 HORSE CREEK RD

| | | | RED BUD | | IL 62278 | | | | | | |
|----------------------|--------------|------------------|---------|-------|----------|-----------|---------|-------|------------|-------|--|
| Site Address: 001500 | | | AMES | | RD | | | | | | |
| MISC | BLDG CODE | DESC | LENGTH | WIDTH | UNITS | ADJ PRICE | EYB DT | PCT | ADJUSTMENT | VALUE | |
| 7 | 4 F-PS1O12 | Pole Shd 1 Sde O | 30.00 | 26.00 | 780.00 | 13.25 | 1966 F3 | 85.00 | 1.00 | 1,550 | |
| 8 | 4 F-PSNE | Pole Shd No Elec | 30.00 | 26.00 | 780.00 | .92 | 1966 F3 | 85.00 | 1.00 | 110- | |
| 9 | 5 F-FRSHED08 | Frame Shed 8' | 32.00 | 30.00 | 960.00 | 22.33 | 1915 F3 | 85.00 | 1.00 | 3,220 | |
| 10 | 6 F-SALV | Salv Farm Buildi | .00 | .00 | 1.00 | 300.00 | 00 FD | 0.00 | 1.00 | 300 | |
| 11 | 7 F-FRSHED18 | Frame Shed 18' | 47.00 | 32.00 | 1504.00 | 21.95 | 1910 F3 | 85.00 | 1.00 | 4,950 | |
| 12 | 8 F-SALV | Salv Farm Buildi | .00 | .00 | 1.00 | 300.00 | 1910 FD | 0.00 | 1.00 | 300 | |
| 13 | 9 F-CONC | Farm Concrete | 47.00 | 26.00 | 1222.00 | 1.83 | 1910 F3 | 85.00 | .50 | 340 | |
| 14 | 10 F-PS4C10 | Pole Shd 4 Sde C | 51.00 | 41.00 | 2091.00 | 12.18 | 1972 F3 | 85.00 | 1.00 | 3,820 | |
| 15 | 10 F-PSNE | Pole Shd No Elec | 51.00 | 41.00 | 2091.00 | .92 | 1972 F3 | 85.00 | 1.00 | 290- | |
| 16 | 11 F-SALV | Salv Farm Buildi | .00 | .00 | 1.00 | 300.00 | 1972 FD | 0.00 | 1.00 | 300 | |
| 17 | 12 F-CONC | Farm Concrete | 51.00 | 7.00 | 357.00 | 1.83 | 1972 F3 | 85.00 | .50 | 100 | |
| 18 | 13 F-SALV | Salv Farm Buildi | .00 | .00 | 1.00 | 300.00 | 00 FD | 0.00 | 1.00 | 300 | |