

Req By: DAWN
JASON & KRISTINE BARTOSIK
1482 CARR ROAD

PART TAX LOT 1A & 1B SUR 734

PRAIRIE DU ROCHER IL 62277

Site Address: 001482 CARR RD

BLDG # 1
 Style/Stories 1.0 One Story
 Quality/Design C C-Average
 Building Use 0100 Single Fami
 Exterior Wall F Frame
 WALL % 100 100%
 Exterior Wall 1
 WALL 1% 000 N/A
 Crawl Sp. Adj
 Slab Adjustment
 Basement
 Combination
 Attic Area
 Heat/AC Adj AC Central Air
 Comb Ht/AC Adj
 Fireplace 03 C-Fireplace
 Extra Fireplace 00 N/A
 Res Fixtures 0012 12 Fixtures
 Garage F Frame Garag
 Integral Garage
 Remodeling Adj 01 No Remodeli
 Actual Year Blt 2002
 Effect Year Blt 2002
 Cond/Desir/Util A Res CDU - A
 Township Multpl 18 TOWNSHIP #1
 Funct. Obs. %
 Economic Obs. %
 Observed Cond %
 Obs. Cond. Code
 Combination A
 Comb A Ht/AC
 Unfin Low/Level
 Full Basement F Full Baseme
 # Of Bedrooms 03 Three Bedro
 Sq.Ft.Grd Area 1590

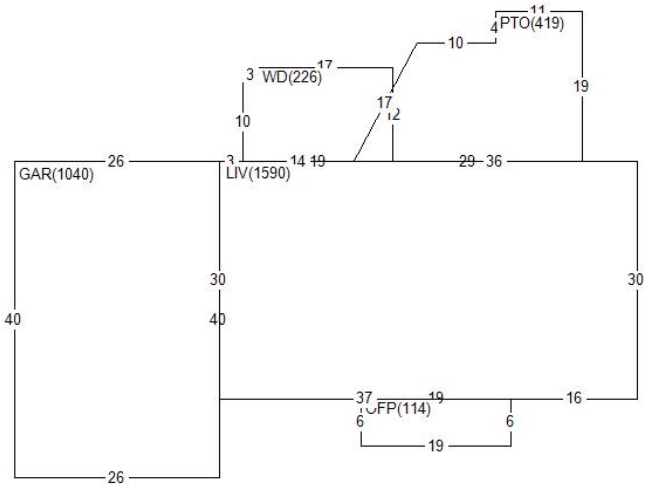

Land Value 28,630
 Misc Value 8,650
 Bldg Value 160,910
 Total Value 198,190
 Value By CAMA

RCN 182,854
 Pct Good 0.8800
 Obsol/Observed 0.0000
 Building Value 160,910

DOCUMENT #	DATE	QS	SALE PRICE
1101	20		
0301	U		40,000

PERMIT NO	TYPE	DATE	AMOUNT
10349	00	0402	
10349	01	0901	

Appraiser KS K. Sondag
 Appr Date 01/03/23
 Use Code 0011 Imp. Farm
 NBHD 1800.31 A-18 1.0 1940/NEW
 L100 M100 B124

AREA	FLAT	EFF%	E/AREA	ACT%	A/AREA	EA/AA	HEATED
OFPP	114	1.00	114	1.00	114	114	
GAR	1040	1.00	1040	1.00	1040	1040	
WD	226	1.00	226	1.00	226	226	
PTO	419	1.00	419	1.00	419	419	
LIV	1590	1.00	1590	1.00	1590	1590	1590

MISC BLDG CODE	DESC	LENGTH	WIDTH	UNITS	ADJ PRICE	EYB DT PCT	ADJUSTMENT	VALUE
1	1 OFPP	6.00	19.00	114.00	25.99	2002 A 12.00	1.00	2,610
2	1 WD	.00	.00	226.00	19.35	2003 A 12.00	1.00	3,850
3	1 PTO	.00	.00	419.00	3.65	2003 A 12.00	1.00	1,350
4	1 SALV	.00	.00	1.00	300.00	00 OD 0.00	1.00	300
5	1 CONDR	14.00	12.00	168.00	3.65	2003 A 12.00	1.00	540

LAND LUSE DESC	ZONING	UNITS TP	PRICE	ADJUSTMENT	CODE/FACTOR	VALUE
1 CD County Road Cat.	MAL	2.50 R	11453.33	TW 1.00	.00 .00 .00	28,630