

Req By: DAWN
RUSSELL & JENNIFER CANDLER
1549 CARR ROAD

PART SE NW & PART TAX LOT 7

PRAIRIE DU ROCHER IL 62277
Site Address: 001549 CARR RD

BLDG # 1
 Style/Stories 1.5 1 1/2 Story
 Quality/Design C C-Average
 Building Use 0100 Single Fami
 Exterior Wall F Frame 1.5
 WALL % 100 100%
 Exterior Wall 1
 WALL 1% 000 N/A
 Crawl Sp. Adj
 Slab Adjustment
 Basement
 Combination F1 Frame/1.0
 Attic Area
 Heat/AC Adj AC Central Air
 Comb Ht/AC Adj AC1 Cent AC Cmb
 Fireplace 03 C-Fireplace
 Extra Fireplace 00 N/A
 Res Fixtures 0015 15 Fixtures
 Garage F Frame Garag
 Integral Garage
 Remodeling Adj 01 No Remodeli
 Actual Year Blt 2019
 Effect Year Blt 2019
 Cond/Desir/Util A Res CDU - A
 Township Multpl 18 TOWNSHIP #1
 Funct. Obs. % 000000
 Economic Obs. % 000000
 Observed Cond % 000000
 Obs. Cond. Code
 Combination A
 Comb A Ht/AC
 Unfin Low/Level
 Full Basement F Full Baseme
 # Of Bedrooms 04 Four Bedroo
 Sq.Ft.Grd Area 1635

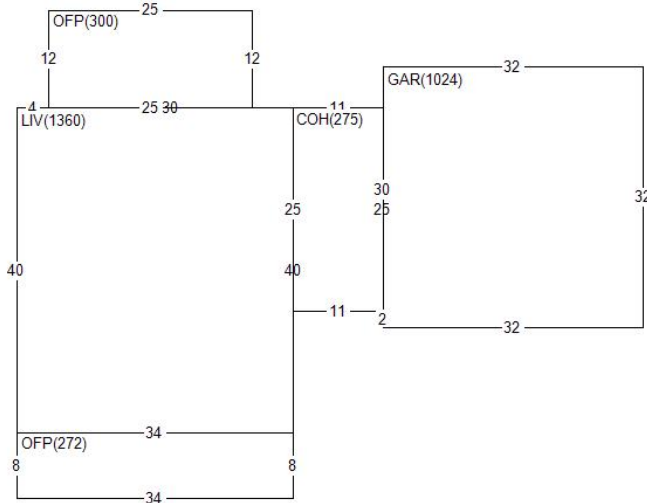

Land Value 28,630
 Misc Value 67,900
 Bldg Value 284,200
 Total Value 380,730
 Value By CAMA

RCN 287,067
 Pct Good 0.9900
 Obsol/Observed 0.0000
 Building Value 284,200

DOCUMENT #	DATE QS	SALE PRICE
387594	1216 07	80,000

PERMIT NO	TYPE	DATE	AMOUNT
14940	00	0919	
14940	01	0519	
14545	00	0218	

Appraiser KS K. Sondag
 Appr Date 01/03/23
 Use Code 0011 Imp. Farm
 NBHD 1800.52 A-18 1.5 1940/NEW
 L100 M100 B143

AREA	FLAT	EFF% E/AREA	ACT% A/AREA	EA/AA HEATED
LIV	1360	1.00	1360 1.00	1360 1360
OFP	572	1.00	572 1.00	572 572
COH	275	1.00	275 1.00	275 275
GAR	1024	1.00	1024 1.00	1024 1024
CONDR	960	1.00	960 1.00	960 960

MISC BLDG CODE	DESC	LENGTH	WIDTH	UNITS	ADJ PRICE	EYB DT PCT	ADJUSTMENT	VALUE
1 1 OFP	Open Frame Porch	8.00	34.00	272.00	23.37	2019 A 1.00	1.00	6,290
2 1 OFP	Open Frame Porch	12.00	25.00	300.00	22.83	2019 A 1.00	1.00	6,780
3 1 CONDR	Concrete Drivewa	30.00	32.00	960.00	3.65	2019 A 1.00	1.00	3,470
4 1 PS1014	Pole Shd 1 Sde O	88.00	48.00	4224.00	10.00	2018 20 25.50	1.00	31,470
5 2 LTP	Lean-to Pole	88.00	19.00	1672.00	5.91	2018 20 25.50	1.00	7,360
6 1 PSCFL	Pole Shd Conc Fl	88.00	48.00	4224.00	3.65	2018 20 25.50	1.00	11,490

LAND LUSE DESC	ZONING	UNITS TP	PRICE	ADJUSTMENT	CODE/FACTOR	VALUE
1 CD County Road Cat.	MAL	2.50 R	11453.33	TW	1.00 .00 .00 .00	28,630

MISC	BLDG CODE	DESC	Site Address:	LENGTH	WIDTH	UNITS	ADJ PRICE	EYB	DT	PCT	ADJUSTMENT	VALUE
			PRAIRIE DU ROCHER IL 62277									
			001549 CARR RD									
7	3 PS4010	Pole Shd 4 Sde O		14.00	14.00	196.00	7.66	2019	20	21.25	1.00	1,180
8	3 PSNE	Pole Shd No Elec		14.00	14.00	196.00	.92	2019	20	21.25	1.00	140-