

TAX LOT 3 & SW NE

PRAIRIE DU ROCHER IL 62277

Site Address: 005570 HICKORY HILL DR

BLDG # 1
 Style/Stories SPL Split-Level
 Quality/Design C C-Average
 Building Use 0100 Single Fami
 Exterior Wall F Frame SPL
 WALL % 100 100%
 Exterior Wall 1
 WALL 1% 000 N/A
 Crawl Sp. Adj C Crawl
 Slab Adjustment
 Basement
 Combination F1 Frame/1.0
 Attic Area
 Heat/AC Adj AC Central Air
 Comb Ht/AC Adj AC1 Cent AC Cmb
 Fireplace 03 C-Fireplace
 Extra Fireplace 00 N/A
 Res Fixtures 0008 08 Fixtures
 Garage F Frame Garag
 Integral Garage
 Remodeling Adj 01 No Remodeli
 Actual Year Blt 1993
 Effect Year Blt 1993
 Cond/Desir/Util A Res CDU - A
 Township Multpl 18 TOWNSHIP #1
 Funct. Obs. %
 Economic Obs. % 000010
 Observed Cond %
 Obs. Cond. Code
 Combination A
 Comb A Ht/AC
 Unfin Low/Level
 Full Basement
 # Of Bedrooms 03 Three Bedro
 Sq.Ft.Grd Area 1739

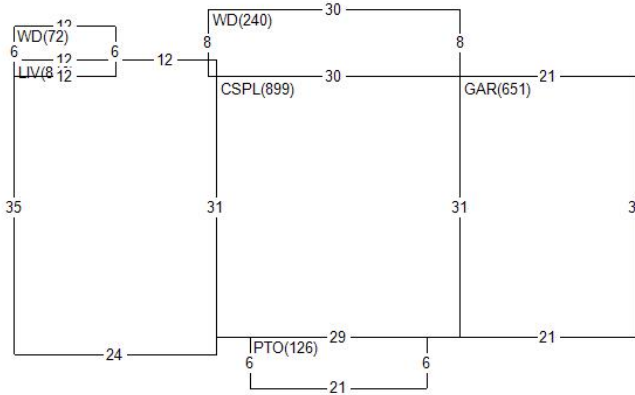

Land Value 34,500
 Misc Value 15,910
 Bldg Value 139,560
 Total Value 189,970
 Value By CAMA

RCN 202,261
 Pct Good 0.7900
 Obsol/Observed 0.1000
 Building Value 139,560

DOCUMENT #	DATE	QS	SALE PRICE
371845	0714	U	
	0591	U	40,000

PERMIT NO	TYPE	DATE	AMOUNT
12382	31	0608	
7026	01	0892	

Appraiser KS K. Sondag
 Appr Date 01/04/23
 Use Code 0040 Imp Res
 NBHD 1800.31 A-18 1.0 1940/NEW
 L100 M100 B124

AREA	FLAT	EFF%	E/AREA	ACT%	A/AREA	EA/AA	HEATED
PTO	279	1.00	279	1.00	279	279	
CRWL	96	1.00	96	1.00	96	96	
SHED	144	1.00	144	1.00	144	144	
LIV	840	1.00	840	1.00	840	840	840
GAR	651	1.00	651	1.00	651	651	
CSPL	899	1.00	899	1.00	899	899	
WD	312	1.00	312	1.00	312	312	

MISC BLDG CODE	DESC	LENGTH	WIDTH	UNITS	ADJ PRICE	EYB DT PCT	ADJUSTMENT	VALUE
1 1 WD	Wood Deck	8.00	30.00	240.00	19.35	2019 A 1.00	1.00	4,600
2 1 WD	Wood Deck	6.00	12.00	72.00	19.35	1993 A 21.00	1.00	1,100
3 1 PTO	Concrete Patio	9.00	17.00	153.00	3.65	1993 A 21.00	1.00	440
5 1 BRVEN	Brick Veneer	24.00	4.00	96.00	14.65	1993 A 21.00	1.00	1,110
6 1 SALV	Salvage Structur	.00	.00	1.00	300.00	00 OD 0.00	1.00	300
7 1 PTO	Concrete Patio	6.00	21.00	126.00	3.65	1999 A 15.00	1.00	390
LAND LUSE DESC	ZONING	UNITS TP	PRICE	ADJUSTMENT CODE/FACTOR			ADJUSTMENT	VALUE
1 CD	County Road Cat.	3.00 R	10225.93	.00	.00	.00 TW	1.00	30,680
2 CD	County Road Cat.	91.00 R	4200.00	TW	1.00 CN	.01	.00	3,820

MISC BLDG CODE		DESC	Site Address:	LENGTH	WIDTH	UNITS	ADJ PRICE	EYB DT	PCT	ADJUSTMENT	VALUE
8	1 PS4C16	Pole Shd 4 Sde C	005570 HICKORY HILL DR	30.00	50.00	1500.00	15.18	2008 20	68.00	1.00	7,290
9	2 LTP	Lean-to Pole		11.00	50.00	550.00	7.05	2008 20	68.00	1.00	1,240
10	1 PSNE	Pole Shd No Elec		50.00	30.00	1500.00	.92	2008 20	68.00	1.00	440-
11	2 LTNE	Lean-To No Elec		50.00	11.00	550.00	.66	2008 20	68.00	1.00	120-