

Req By: DAWN
NICKOLAS L SHARROCK
REBECCA DINNING
3708 STATE ROUTE 3

PART NE SW

RED BUD IL 62278
Site Address: 003708 STATE ROUTE 3

BLDG # 1
 Style/Stories 1.0 One Story
 Quality/Design C C-Average
 Building Use 0100 Single Fami
 Exterior Wall F Frame
 WALL % 100 100%
 Exterior Wall 1
 WALL 1% 000 N/A
 Crawl Sp. Adj
 Slab Adjustment
 Basement
 Combination F15 Frame/1.5
 Attic Area
 Heat/AC Adj AC Central Air
 Comb Ht/AC Adj AC15 Cent AC Cmb
 Fireplace 00 N/A
 Extra Fireplace 00 N/A
 Res Fixtures 0011 11 Fixtures
 Garage F Frame Garag
 Integral Garage
 Remodeling Adj 01 No Remodeli
 Actual Year Blt 1991
 Effect Year Blt 1991
 Cond/Desir/Util A Res CDU - A
 Township Multpl 16 TOWNSHIP #1
 Funct. Obs. % 000000
 Economic Obs. % 000000
 Observed Cond % 000000

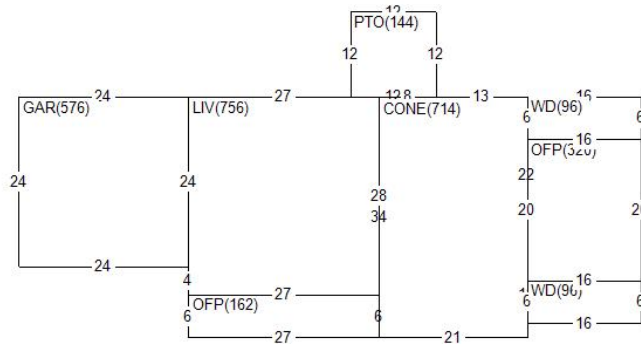

Land Value 38,860
 Misc Value 68,150
 Bldg Value 188,720
 Total Value 295,730
 Value By CAMA

RCN 245,091
 Pct Good 0.7700
 Obsol/Observed 0.0000
 Building Value 188,720

DOCUMENT #	DATE	QS	SALE PRICE
371302	0614	U	174,000
358644	0912	U	
	0298	Q	159,500

PERMIT NO	TYPE	DATE	AMOUNT
14303	00	0518	
14303	07	0317	
14922	05	0419	

Appraiser KS K. Sondag
 Appr Date 11/16/22
 Use Code 0040 Imp Res
 NBHD 1600.31 A-16 1.0 1940/NEW
 L100 M100 B153

AREA	FLAT	EFF% E/AREA	ACT% A/AREA	EA/AA HEATED
GAR	576	1.00	576 1.00	576 576
OFF	482	1.00	482 1.00	482 482
PTO	144	1.00	144 1.00	144 144
CONE	714	1.00	714 1.00	714 714
LIV	756	1.00	756 1.00	756 756 756
SHED	1056	1.00	1056 1.00	1056 1056
WD	192	1.00	192 1.00	192 192

MISC BLDG CODE	DESC	LENGTH	WIDTH	UNITS	ADJ PRICE	EYB DT PCT	ADJUSTMENT	VALUE
1 1 OFP	Open Frame Porch	6.00	27.00	162.00	23.73	1991 A 23.00	1.00	2,960
3 1 PTO	Concrete Patio	12.00	12.00	144.00	3.65	1991 A 23.00	1.00	410
5 1 PS4C10	Pole Shd 4 Sde C	24.00	44.00	1056.00	13.95	1991 20 85.00	1.00	2,210
6 1 OFP	Open Frame Porch	31.00	36.00	1116.00	19.80	2015 A 3.00	1.00	21,430
7 1 CONDR	Concrete Drivewa	16.00	12.00	192.00	3.65	2015 A 3.00	1.00	680
8 1 CONDR	Concrete Drivewa	24.00	16.00	384.00	3.65	2015 A 3.00	1.00	1,360

LAND LUSE DESC	ZONING	UNITS TP	PRICE	ADJUSTMENT	CODE/FACTOR	VALUE
1 CD County Road Cat.	MAL	5.00 R	7771.11	.00	.00 TW 1.00	38,860

Req By: DAWN
 NICKOLAS L SHARROCK
 REBECCA DINNING
 3708 STATE ROUTE 3

MISC BLDG CODE		DESC	LENGTH	WIDTH	UNITS	ADJ PRICE	EYB DT	PCT	ADJUSTMENT	VALUE
9	1 CPTMTL	Carport Metal	20.00	27.00	540.00	3.33	2015 A	3.00	1.00	1,740
10	1 PS4C18	Pole Shd 4 Sde C	40.00	60.00	2400.00	14.32	2015 20	38.25	1.00	21,220
11	1 OFP	Open Frame Porch	16.00	20.00	320.00	22.61	2018 A	2.00	1.00	7,090
12	1 WD	Wood Deck	16.00	6.00	96.00	19.35	2018 A	2.00	1.00	1,820
13	1 WD	Wood Deck	16.00	6.00	96.00	19.35	2018 A	2.00	1.00	1,820
14	2 PSCFL	Pole Shd Conc Fl	60.00	40.00	2400.00	3.65	2015 20	38.25	1.00	5,410

RED BUD IL 62278
 Site Address: 003708 STATE ROUTE 3