

PART NE SE

RED BUD IL 62278  
 Site Address: 003506 STATE ROUTE 3

BLDG # 1  
 Style/Stories 1.0 One Story  
 Quality/Design C C-Average  
 Building Use 0100 Single Fami  
 Exterior Wall F Frame  
 WALL % 100 100%  
 Exterior Wall 1  
 WALL 1% 000 N/A  
 Crawl Sp. Adj  
 Slab Adjustment S Slab  
 Basement  
 Combination  
 Attic Area  
 Heat/AC Adj AC Central Air  
 Comb Ht/AC Adj  
 Fireplace 00 N/A  
 Extra Fireplace 00 N/A  
 Res Fixtures 0010 10 Fixtures  
 Garage F Frame Garag  
 Integral Garage  
 Remodeling Adj 01 No Remodeli  
 Actual Year Blt 1991  
 Effect Year Blt 1991  
 Cond/Desir/Util A Res CDU - A  
 Township Multpl 16 TOWNSHIP #1  
 Funct. Obs. % 000000  
 Economic Obs. % 000000  
 Observed Cond % 000000  
 Obs. Cond. Code  
 Combination A  
 Comb A Ht/AC  
 Unfin Low/Level  
 Full Basement  
 # Of Bedrooms 03 Three Bedro  
 Sq.Ft.Grnd Area 2016

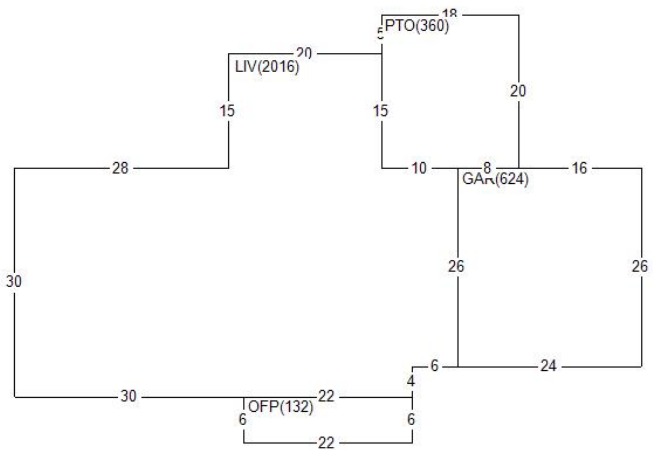

Land Value 28,630  
 Misc Value 23,780  
 Bldg Value 175,020  
 Total Value 227,430  
 Value By CAMA

RCN 227,298  
 Pct Good 0.7700  
 Obsol/Observed 0.0000  
 Building Value 175,020

DOCUMENT # DATE QS SALE PRICE  
 0591 07

PERMIT NO TYPE DATE AMOUNT  
 15051 00 1219  
 15051 02 1019  
 13617 00 0315  
 Appraiser KS K. Sondag  
 Appr Date 11/16/22  
 Use Code 0040 Imp Res  
 NBHD 1600.31 A-16 1.0 1940/NEW  
 L100 M100 B153

AREA	FLAT	EFF% E/AREA	ACT% A/AREA	EA/AA HEATED
OFF	132	1.00	132	132
GAR	624	1.00	624	624
LIV	2016	1.00	2016	2016
CONDR	400	1.00	400	400
PTO	360	1.00	360	360
SLAB	300	1.00	300	300

MISC BLDG CODE	DESC	LENGTH	WIDTH	UNITS	ADJ PRICE	EYB DT PCT	ADJUSTMENT	VALUE
1 1 OFFP	Open Frame Porch	6.00	22.00	132.00	24.86	1991 A 23.00	1.00	2,530
2 1 PTO	Concrete Patio	18.00	20.00	360.00	3.65	2015 A 3.00	1.00	1,280
3 1 CONDR	Concrete Drivewa	30.00	20.00	600.00	3.65	1999 F 23.00	1.00	1,690
4 1 CONDR	Concrete Drivewa	20.00	20.00	400.00	3.65	1999 A 15.00	1.00	1,240
5 1 SHED	Frame Shed	30.00	24.00	720.00	23.91	2019 A 1.00	1.00	17,040

LAND LUSE DESC	ZONING	UNITS TP	PRICE	ADJUSTMENT	CODE/FACTOR	VALUE
1 CD County Road Cat.	MAL	2.50 R	11453.33	.00	.00 TW 1.00	28,630