

PART SW 1/4 SW 1/4

RED BUD IL 62278  
Site Address: 006007 MM RD

BLDG # 1  
Style/Stories 1.0 One Story  
Quality/Design C C-Average  
Building Use 0100 Single Fami  
Exterior Wall F Frame  
WALL % 100 100%  
Exterior Wall 1  
WALL 1% 000 N/A  
Crawl Sp. Adj  
Slab Adjustment  
Basement RC C-Rec Room  
Combination  
Attic Area  
Heat/AC Adj AC Central Air  
Comb Ht/AC Adj  
Fireplace 03 C-Fireplace  
Extra Fireplace 00 N/A  
Res Fixtures 0018 18 Fixtures  
Garage F Frame Garag  
Integral Garage  
Remodeling Adj 01 No Remodeli  
Actual Year Blt 2020  
Effect Year Blt 2020  
Cond/Desir/Util A Res CDU - A  
Township Multpl 16 TOWNSHIP #1  
Funct. Obs. % 000000  
Economic Obs. % 000000  
Observed Cond % 000000  
Obs. Cond. Code  
Combination A  
Comb A Ht/AC  
Unfin Low/Level  
Full Basement F Full Baseme  
# Of Bedrooms 04 Four Bedroo  
Sq.Ft.Grnd Area 2582

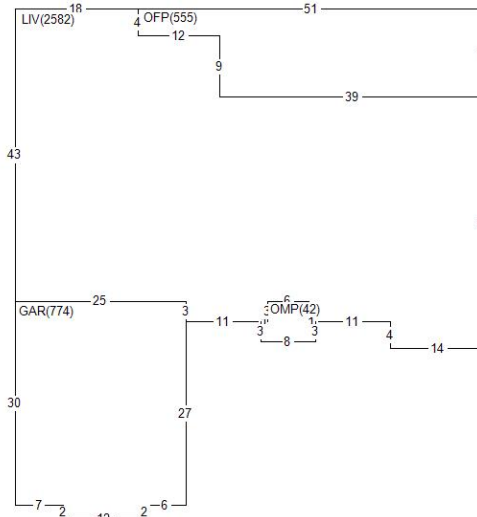

Land Value 59,300  
Misc Value 79,380  
Bldg Value 331,650  
Total Value 470,330  
Value By CAMA

RCN 334,997  
Pct Good 0.9900  
Obsol/Observed 0.0000  
Building Value 331,650

DOCUMENT # DATE QS SALE PRICE  
406596 0320 Q 80,000

PERMIT NO TYPE DATE AMOUNT  
15751 00 1222  
15751 05 1021  
15286 00 1220  
Appraiser JB J. Brown  
Appr Date 03/28/24  
Use Code 0040 Imp Res  
NBHD 1600.31 A-16 1.0 1940/NEW  
L100 M100 B153

AREA	FLAT	EFF%	E/AREA	ACT%	A/AREA	EA/AA	HEATED
LIV	2582	1.00	2582	1.00	2582	2582	2582
GAR	774	1.00	774	1.00	774	774	
OMP	42	1.00	42	1.00	42	42	
OFFP	555	1.00	555	1.00	555	555	
BSMR	1325	1.00	1325	1.00	1325	1325	

MISC BLDG CODE	DESC	LENGTH	WIDTH	UNITS	ADJ PRICE	EYB DT PCT	ADJUSTMENT	VALUE
1 1 OMP	Open Masonry Por	.00	.00	42.00	46.75	2020 A 1.00	1.00	1,940
2 1 OFFP	Open Frame Porch	.00	.00	555.00	20.89	2020 A 1.00	1.00	11,480
3 1 BRVEN	Brick Veneer	.00	.00	374.00	14.65	2020 A 1.00	1.00	5,420
4 1 GARF	Garage Frame	45.00	70.00	3150.00	19.22	2022 A 0.00	1.00	60,540

LAND LUSE DESC	ZONING	UNITS TP	PRICE	ADJUSTMENT	CODE/FACTOR	VALUE
1 CD County Road Cat.	MA1	10.00 R	5930.00	.00	.00 TW 1.00	59,300