

Req By: DAWN  
TRAVIS BRANSON  
3878 OLD STATE ROUTE 3

TAX LOT 7C

RED BUD IL 62278  
Site Address: 003878 OLD STATE ROUTE 3

BLDG # 1  
 Style/Stories 1.0 One Story  
 Quality/Design C C-Average  
 Building Use 0100 Single Fami  
 Exterior Wall M Masonry 1.0  
 WALL % 075 075%  
 Exterior Wall 1 F Frame  
 WALL 1% 025 025%  
 Crawl Sp. Adj C Crawl  
 Slab Adjustment  
 Basement  
 Combination  
 Attic Area  
 Heat/AC Adj  
 Comb Ht/AC Adj  
 Fireplace 00 N/A  
 Extra Fireplace 00 N/A  
 Res Fixtures 0005 05 Fixtures  
 Garage F Frame Garag  
 Integral Garage  
 Remodeling Adj 03 Partial Upd  
 Actual Year Blt 1969  
 Effect Year Blt 1969  
 Cond/Desir/Util A Res CDU - A  
 Township Multpl 16 TOWNSHIP #1  
 Funct. Obs. % 000000  
 Economic Obs. % 000000  
 Observed Cond % 000000  
 Obs. Cond. Code  
 Combination A  
 Comb A Ht/AC  
 Unfin Low/Level  
 Full Basement  
 # Of Bedrooms 03 Three Bedro  
 Sq.Ft.Grd Area 1554

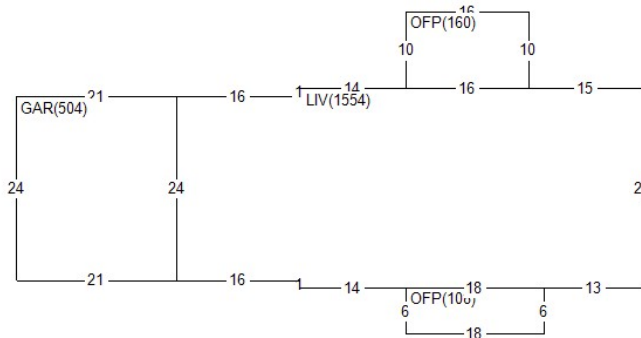

Land Value 26,590  
 Misc Value 48,920  
 Bldg Value 105,370  
 Total Value 180,880  
 Value By CAMA

RCN 191,581  
 Pct Good 0.5500  
 Obsol/Observed 0.0000  
 Building Value 105,370

DOCUMENT #	DATE	QS	SALE PRICE
401886	0619	U	
	1098	Q	108,000
	0797	Q	94,000

PERMIT NO	TYPE	DATE	AMOUNT
MC2024-282	00	0125	
MC2024-282	31	1024	
5332	05	0987	

Appraiser KS K. Sondag  
 Appr Date 11/03/25  
 Use Code 0040 Imp Res  
 NBHD 1600.31 A-16 1.0 1940/NEW  
 L100 M100 B178

AREA	FLAT	EFF% E/AREA	ACT% A/AREA	EA/AA	HEATED
OFF	268	1.00	268	1.00	268
LIV	1554	1.00	1554	1.00	1554
CRWL	1554	1.00	1554	1.00	1554
GAR	504	1.00	504	1.00	504

MISC BLDG CODE	DESC	LENGTH	WIDTH	UNITS	ADJ PRICE	EYB DT	PCT	ADJUSTMENT	VALUE
1 1	OFF Open Frame Porch	6.00	18.00	108.00	26.42	1969 A	45.00	1.00	1,570
2 1	OFF Open Frame Porch	10.00	16.00	160.00	23.77	1969 A	45.00	1.00	2,090
4 1	GARF Garage Frame	22.00	16.00	352.00	19.21	1987 F	36.00	1.00	4,330
6 1	SHED Frame Shed	7.00	8.00	56.00	26.82	1969 P	60.00	1.00	600
7 1	SHED Frame Shed	8.00	12.00	96.00	26.69	2015 A	3.00	1.00	2,490
8 1	PS4C16 Pole Shd 4 Sde C	48.00	40.00	1920.00	14.63	2024 20	4.25	1.00	26,900

LAND LUSE DESC	ZONING	UNITS TP	PRICE	ADJUSTMENT	CODE/FACTOR	VALUE
1 CD County Road Cat.	MAL	2.00 R	13294.44	.00	.00	26,590

Req By: DAWN  
TRAVIS BRANSON  
3878 OLD STATE ROUTE 3

MISC BLDG CODE	DESC	Site Address:	RED BUD LENGTH	WIDTH	UNITS	IL 62278 ADJ PRICE	EYB DT	PCT	ADJUSTMENT	VALUE
9 1 PSCFL	Pole Shd Conc Fl	003878	48.00	40.00	1920.00	3.65	2024 20	4.25	1.00	6,710
10 2 LTP	Lean-to Pole		40.00	16.00	640.00	6.90	2024 20	4.25	1.00	4,230