

LOT 45 BLUFF MEADOWS

VALMEYER IL 62295

Site Address: 000401 CLIFF VIEW PL

BLDG # 1
 Style/Stories 1.0 One Story
 Quality/Design C C-Average
 Building Use 0100 Single Fami
 Exterior Wall F Frame
 WALL % 100 100%
 Exterior Wall 1
 WALL 1% 000 N/A
 Crawl Sp. Adj
 Slab Adjustment
 Basement RC C-Rec Room
 Combination
 Attic Area
 Heat/AC Adj AC Central Air
 Comb Ht/AC Adj
 Fireplace 31 DirectVent
 Extra Fireplace 00 N/A
 Res Fixtures 0012 12 Fixtures
 Garage F Frame Garag
 Integral Garage
 Remodeling Adj 01 No Remodeli
 Actual Year Blt 2006
 Effect Year Blt 2006
 Cond/Desir/Util A Res CDU - A
 Township Multpl 06 TOWNSHIP #0
 Funct. Obs. %
 Economic Obs. %
 Observed Cond %
 Obs. Cond. Code
 Combination A
 Comb A Ht/AC
 Unfin Low/Level
 Full Basement F Full Baseme
 # Of Bedrooms 03 Three Bedro
 Sq.Ft.Grnd Area 1997

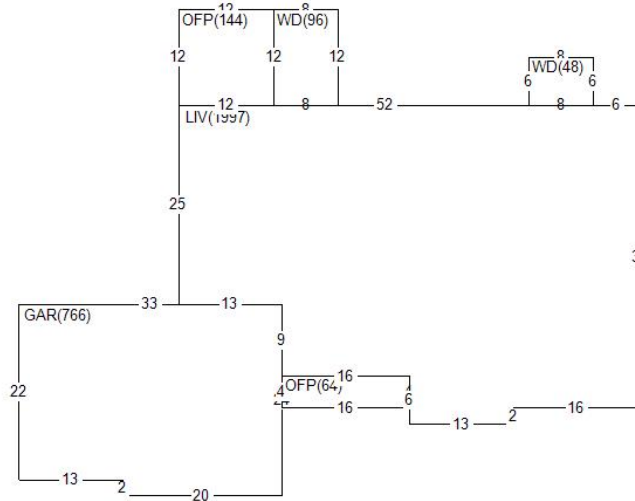

Land Value 26,760
 Misc Value 20,260
 Bldg Value 259,520
 Total Value 306,540
 Value By CAMA

RCN 285,184
 Pct Good 0.9100
 Obsol/Observed 0.0000
 Building Value 259,520

DOCUMENT #	DATE	QS	SALE PRICE
416320	0421	U	270,000
385830	0916	U	
371327	0614	Q	257,000
PERMIT NO	TYPE	DATE	AMOUNT
R1-06-23	01	0606	

Appraiser KS K. Sondag
 Appr Date 07/20/22
 Use Code 0040 Imp Res
 NBHD 62000.10 VLMYR 1.0 STORY
 L100 M100 B169

AREA	FLAT	EFF%	E/AREA	ACT%	A/AREA	EA/AA	HEATED
PTO	320	1.00	320	1.00	320	320	
CONDR	1131	1.00	1131	1.00	1131	1131	
BSMR	999	1.00	999	1.00	999	999	
WD	144	1.00	144	1.00	144	144	
GAR	766	1.00	766	1.00	766	766	
OFF	208	1.00	208	1.00	208	208	
LIV	1997	1.00	1997	1.00	1997	1997	1997

MISC BLDG CODE	DESC	LENGTH	WIDTH	UNITS	ADJ PRICE	EYB DT PCT	ADJUSTMENT	VALUE
1	1 OFF	4.00	16.00	64.00	31.88	2006 A 9.00	1.00	1,860
2	1 WD	6.00	8.00	48.00	19.35	2006 A 9.00	1.00	850
3	1 WD	12.00	8.00	96.00	19.35	2006 A 9.00	1.00	1,690
4	1 PTO	16.00	20.00	320.00	3.65	2006 A 9.00	1.00	1,060
5	1 CONDR	.00	.00	1131.00	3.65	2006 A 9.00	1.00	3,760
6	1 BRVEN	.00	.00	584.00	14.65	2006 A 9.00	1.00	7,790
LAND LUSE DESC	ZONING	UNITS	TP	PRICE	ADJUSTMENT	CODE/FACTOR	ADJUSTMENT	VALUE
1 6200 VALMEYER	VR1	1.00	ST	26760.00	TW	1.00	.00 .00 .00	26,760

MISC BLDG CODE	DESC	Site Address:	VALMEYER	IL 62295	CLIFF VIEW	PL	ADJ PRICE	EYB DT PCT	ADJUSTMENT	VALUE
		LENGTH	WIDTH	UNITS						
7 1 OFP	Open Frame Porch	12.00	12.00	144.00			24.29	2008 A 7.00	1.00	3,250