

LOT 262 NEW VALMEYER PHASE 5

VALMEYER IL 62295

Site Address: 000125 N CEDAR BLUFF DR

BLDG # 1  
 Style/Stories 2.0 2 Story  
 Quality/Design C C-Average  
 Building Use 0100 Single Fami  
 Exterior Wall F Frame 2.0  
 WALL % 100 100%  
 Exterior Wall 1  
 WALL 1% 000 N/A  
 Crawl Sp. Adj  
 Slab Adjustment  
 Basement  
 Combination F1 Frame/1.0  
 Attic Area  
 Heat/AC Adj AC Central Air  
 Comb Ht/AC Adj AC1 Cent AC Cmb  
 Fireplace 00 N/A  
 Extra Fireplace 00 N/A  
 Res Fixtures 0008 08 Fixtures  
 Garage F Frame Garag  
 Integral Garage  
 Remodeling Adj 01 No Remodeli  
 Actual Year Blt 1995  
 Effect Year Blt 1995  
 Cond/Desir/Util A Res CDU - A  
 Township Multpl 06 TOWNSHIP #0  
 Funct. Obs. % 000000  
 Economic Obs. % 000000  
 Observed Cond % 000000  
 Obs. Cond. Code  
 Combination A  
 Comb A Ht/AC  
 Unfin Low/Level  
 Full Basement F Full Baseme  
 # Of Bedrooms 03 Three Bedro  
 Sq.Ft.Grd Area 1361

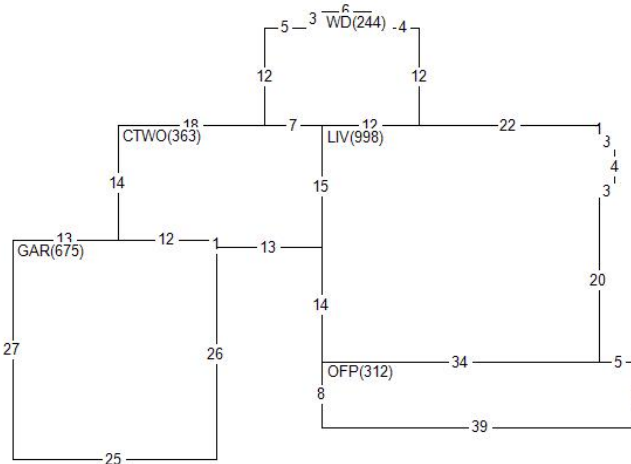

Land Value 26,760  
 Misc Value 14,700  
 Bldg Value 158,220  
 Total Value 199,680  
 Value By CAMA

RCN 195,335  
 Pct Good 0.8100  
 Obsol/Observed 0.0000  
 Building Value 158,220

DOCUMENT #	DATE	QS	SALE PRICE
434443	0924	U	150,000
425779	0822	U	55,000
425244	0722	U	

PERMIT NO	TYPE	DATE	AMOUNT
R1-01-16	10	0801	
R1-95-26	01	0995	

Appraiser AS A. Schwar  
 Appr Date 10/03/24  
 Use Code 0040 Imp Res  
 NBHD 62000.20 VLMYR 2.0 STORY  
 L100 M100 B116

AREA	FLAT	EFF%	E/AREA	ACT%	A/AREA	EA/AA	HEATED
OFP	312	1.00	312	1.00	312	312	
GAR	675	1.00	675	1.00	675	675	
CTWO	363	1.00	363	1.00	363	363	
WD	244	1.00	244	1.00	244	244	
LIV	998	1.00	998	1.00	998	998	998
CONDR	1375	1.00	1375	1.00	1375	1375	

MISC BLDG CODE	DESC	LENGTH	WIDTH	UNITS	ADJ PRICE	EYB DT PCT	ADJUSTMENT	VALUE
1 1 OFP	Open Frame Porch	8.00	39.00	312.00	22.70	1995 P 34.00	1.00	4,670
2 1 WD	Wood Deck	.00	.00	244.00	19.35	2002 F 20.00	1.00	3,780
3 1 WD	Wood Deck	.00	.00	117.00	19.35	2003 F 19.00	1.00	1,830
4 1 CONDR	Concrete Drivewa	55.00	25.00	1375.00	3.65	2003 A 12.00	1.00	4,420

LAND LUSE DESC	ZONING	UNITS TP	PRICE	ADJUSTMENT	CODE/FACTOR	VALUE
1 6200 VALMEYER	VR1	1.00 ST	26760.00	.00	.00 TW 1.00	26,760