

Req By: DAWN  
BRYCE N TOENJES &  
NICOLE KREHER  
100 N CEDAR BLUFF DR

LOT 308 NEW VALMEYER PHASE 5

VALMEYER IL 62295

Site Address: 000100 N CEDAR BLUFF DR

BLDG # 1  
 Style/Stories 1.0 One Story  
 Quality/Design C C-Average  
 Building Use 0100 Single Fami  
 Exterior Wall F Frame  
 WALL % 060 060%  
 Exterior Wall 1 M Masonry  
 WALL 1% 040 040%  
 Crawl Sp. Adj  
 Slab Adjustment  
 Basement  
 Combination  
 Attic Area  
 Heat/AC Adj AC Central Air  
 Comb Ht/AC Adj  
 Fireplace 00 N/A  
 Extra Fireplace 00 N/A  
 Res Fixtures 0010 10 Fixtures  
 Garage F Frame Garag  
 Integral Garage  
 Remodeling Adj 01 No Remodeli  
 Actual Year Blt 1995  
 Effect Year Blt 1995  
 Cond/Desir/Util A Res CDU - A  
 Township Multpl 06 TOWNSHIP #0  
 Funct. Obs. % 000000  
 Economic Obs. % 000000  
 Observed Cond % 000000  
 Obs. Cond. Code  
 Combination A  
 Comb A Ht/AC  
 Unfin Low/Level  
 Full Basement F Full Baseme  
 # Of Bedrooms 03 Three Bedro  
 Sq.Ft.Gr'd Area 1566

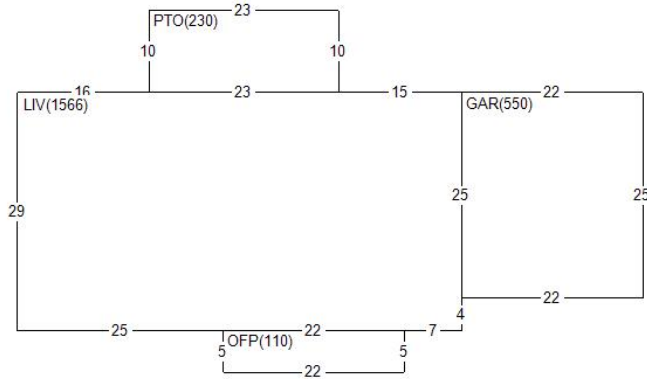

Land Value 26,760  
 Misc Value 9,640  
 Bldg Value 180,240  
 Total Value 216,640  
 Value By CAMA

RCN 222,524  
 Pct Good 0.8100  
 Obsol/Observed 0.0000  
 Building Value 180,240

DOCUMENT #	DATE	QS	SALE PRICE
427784	0223	Q	185,000
389094	0417	Q	125,000
285359	0304	Q	138,500
PERMIT NO	TYPE	DATE	AMOUNT
R1-97-05	10	0597	
R1-94-47	01	1194	

Appraiser AS A. Schwar  
 Appr Date 03/02/23  
 Use Code 0040 Imp Res  
 NBHD 62000.10 VLMYR 1.0 STORY  
 L100 M100 B169

AREA	FLAT	EFF% E/AREA	ACT% A/AREA	EA/AA HEATED
OFFP	110	1.00	110	110
GAR	550	1.00	550	550
LIV	1566	1.00	1566	1566
CONDR	918	1.00	918	918
WD	170	1.00	170	170
PTO	230	1.00	230	230

MISC BLDG CODE	DESC	LENGTH	WIDTH	UNITS	ADJ PRICE	EYB DT	PCT	ADJUSTMENT	VALUE
1	1 OFFP	5.00	22.00	110.00	26.28	1995 A	19.00	1.00	2,340
2	1 CONDR	51.00	18.00	918.00	3.65	1995 F	27.00	1.00	2,450
4	1 BRVEN	.00	.00	64.00	14.65	1995 A	19.00	1.00	760
5	1 WD	17.00	10.00	170.00	19.35	2019 A	1.00	1.00	3,260
6	1 PTO	23.00	10.00	230.00	3.65	2019 A	1.00	1.00	830

LAND LUSE DESC	ZONING	UNITS TP	PRICE	ADJUSTMENT CODE/FACTOR	VALUE
1 6200 VALMEYER	VR1	1.00 ST	26760.00	.00 .00 .00 TW 1.00	26,760