

LOT 338 NEW VALMEYER PHASE 5

VALMEYER IL 62295  
Site Address: 000207 STONEHILL RIDGE

BLDG # 1  
 Style/Stories 1.0 One Story  
 Quality/Design C C-Average  
 Building Use 0100 Single Fami  
 Exterior Wall F Frame  
 WALL % 060 060%  
 Exterior Wall 1 M Masonry  
 WALL 1% 040 040%  
 Crawl Sp. Adj C Crawl  
 Slab Adjustment  
 Basement  
 Combination  
 Attic Area  
 Heat/AC Adj AC Central Air  
 Comb Ht/AC Adj  
 Fireplace 31 DirectVent  
 Extra Fireplace 00 N/A  
 Res Fixtures 0012 12 Fixtures  
 Garage F Frame Garag  
 Integral Garage  
 Remodeling Adj 01 No Remodeli  
 Actual Year Blt 2004  
 Effect Year Blt 2004  
 Cond/Desir/Util A Res CDU - A  
 Township Multpl 06 TOWNSHIP #0  
 Funct. Obs. %  
 Economic Obs. %  
 Observed Cond %  
 Obs. Cond. Code  
 Combination A  
 Comb A Ht/AC  
 Unfin Low/Level  
 Full Basement F Full Baseme  
 # Of Bedrooms 04 Four Bedroo  
 Sq.Ft.Grđ Area 2098

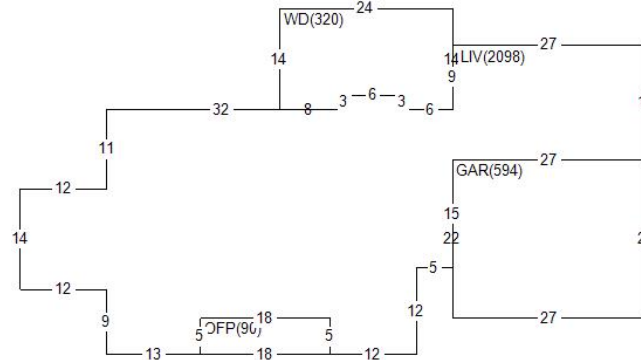

Land Value 26,760  
 Misc Value 29,610  
 Bldg Value 268,600  
 Total Value 324,970  
 Value By CAMA

RCN 301,793  
 Pct Good 0.8900  
 Obsol/Observed 0.0000  
 Building Value 268,600

DOCUMENT # DATE QS SALE PRICE  
 0602 Q 25,509

PERMIT NO TYPE DATE AMOUNT  
 R1-19-03 05 0319  
 R1-06-06 04 0406  
 R1-04-25 01 0604  
 Appraiser JB J. Brown  
 Appr Date 07/11/22  
 Use Code 0040 Imp Res  
 NBHD 62000.10 VLMYR 1.0 STORY  
 L100 M100 B169

AREA	FLAT	EFF% E/AREA	ACT% A/AREA	EA/AA	HEATED
OFFP	90	1.00	90	1.00	90
GAR	594	1.00	594	1.00	594
WD	320	1.00	320	1.00	320
LIV	2098	1.00	2098	1.00	2098
CONDR	1764	1.00	1764	1.00	1764
CRWL	16	1.00	16	1.00	16
SHED	288	1.00	288	1.00	288
CPT	505	1.00	505	1.00	505

MISC BLDG CODE	DESC	LENGTH	WIDTH	UNITS	ADJ PRICE	EYB DT PCT	ADJUSTMENT	VALUE
1 1 OFP	Open Frame Porch	5.00	18.00	90.00	28.19	2004 A 11.00	1.00	2,260
2 1 CONDR	Concrete Drivewa	55.00	23.00	1265.00	3.65	2004 A 11.00	1.00	4,110
3 1 DORM	Dormer	.00	.00	1.00	1850.00	00 OD 0.00	1.00	1,850
4 1 BRVEN	Brick Veneer	.00	.00	272.00	14.65	2004 A 11.00	1.00	3,550
5 1 WD	Wood Deck	.00	.00	320.00	19.35	2005 A 10.00	1.00	5,570
6 1 SHED	Frame Shed	12.00	24.00	288.00	26.05	2006 A 9.00	1.00	6,830
LAND LUSE DESC	ZONING	UNITS TP	PRICE	ADJUSTMENT	CODE/FACTOR	ADJUSTMENT	VALUE	
1 6200 VALMEYER	VR1	1.00 ST	26760.00	TW 1.00	.00	.00	.00	26,760

MISC BLDG CODE		DESC	Site Address:	VALMEYER	IL 62295	STONEHILL RIDGE			ADJUSTMENT	VALUE
			000207	LENGTH	WIDTH	UNITS	ADJ PRICE	EYB DT PCT		
7	1 CPTMTL	Carport Metal		11.00	23.00	253.00	4.10	2019 A 1.00	1.00	1,030
8	1 CPTMTL	Carport Metal		12.00	21.00	252.00	4.10	2019 A 1.00	1.00	1,020
9	1 CONDR	Concrete Drivewa		.00	.00	499.00	3.65	2019 A 1.00	1.00	1,800
10	1 SHED	Frame Shed		12.00	5.00	60.00	26.81	2019 A 1.00	1.00	1,590