

LOT 1 BLUFF MEADOWS

VALMEYER IL 62295
Site Address: 000414 BLUFF MEADOWS DR

BLDG # 1
 Style/Stories 1.0 One Story
 Quality/Design C C-Average
 Building Use 0100 Single Fami
 Exterior Wall F Frame
 WALL % 100 100%
 Exterior Wall 1
 WALL 1% 000 N/A
 Crawl Sp. Adj C Crawl
 Slab Adjustment
 Basement
 Combination
 Attic Area
 Heat/AC Adj AC Central Air
 Comb Ht/AC Adj
 Fireplace DirectVent
 Extra Fireplace 00 N/A
 Res Fixtures 0010 10 Fixtures
 Garage F Frame Garag
 Integral Garage
 Remodeling Adj 01 No Remodeli
 Actual Year Blt 2006
 Effect Year Blt 2006
 Cond/Desir/Util A
 Township Multpl 06 Res CDU - A
 Funct. Obs. % TOWNSHIP #0
 Economic Obs. %
 Observed Cond %
 Obs. Cond. Code
 Combination A
 Comb A Ht/AC
 Unfin Low/Level
 Full Basement F Full Baseme
 # Of Bedrooms 03 Three Bedro
 Sq.Ft.Grd Area 1796 GAR

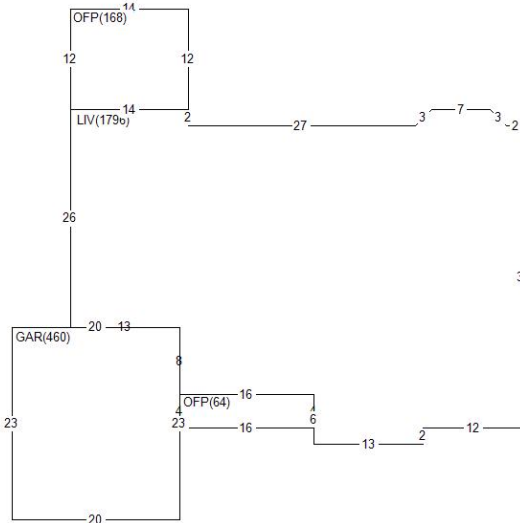

Land Value 26,760
 Misc Value 12,870
 Bldg Value 218,170
 Total Value 257,800
 Value By CAMA

RCN 239,748
 Pct Good 0.9100
 Obsol/Observed 0.0000
 Building Value 218,170

DOCUMENT #	DATE	QS	SALE PRICE
326551	0908	Q	243,800
306994	0606	U	35,625

PERMIT NO	TYPE	DATE	AMOUNT
R2-08-04	07	0908	
R1-06-11	01	0506	

Appraiser KS K. Sondag
 Appr Date 07/20/22
 Use Code 0040 Imp Res
 NBHD 62000.10 VLMYR 1.0 STORY
 L100 M100 B169

AREA	FLAT	EFF% E/AREA	ACT% A/AREA	EA/AA HEATED
CRWL	18	1.00	18	18
CONDR	630	1.00	630	630
OFFP	232	1.00	232	232
LIV	1796	1.00	1796	1796
GAR	460	1.00	460	460

MISC BLDG CODE	DESC	LENGTH	WIDTH	UNITS	ADJ PRICE	EYB DT PCT	ADJUSTMENT	VALUE
1 1 OFFP	Open Frame Porch	4.00	16.00	64.00	31.88	2006 A 9.00	1.00	1,860
2 1 OFFP	Open Frame Porch	12.00	14.00	168.00	23.59	2009 A 7.00	1.00	3,690
3 1 CONDR	Concrete Drivewa	35.00	18.00	630.00	3.65	2006 A 9.00	1.00	2,090
4 1 BRVEN	Brick Veneer	.00	.00	392.00	14.65	2006 A 9.00	1.00	5,230

LAND LUSE DESC	ZONING	UNITS TP	PRICE	ADJUSTMENT	CODE/FACTOR	VALUE
1 6200 VALMEYER	VR1	1.00 ST	26760.00	TW 1.00	.00 .00	26,760