

PART TAX LOTS 7 & 8

COLUMBIA IL 62236
Site Address: 000000 GILMORE LAKE RD

BLDG # 1
Style/Stories 1.0 One Story
Quality/Design C C-Average
Building Use 0100 Single Fami
Exterior Wall F Frame
WALL % 100 100%
Exterior Wall 1
WALL 1% 000 N/A
Crawl Sp. Adj C Crawl
Slab Adjustment
Basement
Combination
Attic Area
Heat/AC Adj AC Central Air
Comb Ht/AC Adj
Fireplace 03 C-Fireplace
Extra Fireplace 00 N/A
Res Fixtures 0012 12 Fixtures
Garage F Frame Garag
Integral Garage
Remodeling Adj 01 No Remodeli
Actual Year Blt 2007
Effect Year Blt 2007
Cond/Desir/Util A Res CDU - A
Township Multpl 05 TOWNSHIP #0
Funct. Obs. %
Economic Obs. %
Observed Cond %
Obs. Cond. Code
Combination A
Comb A Ht/AC
Unfin Low/Level
Full Basement F Full Baseme
Of Bedrooms 03 Three Bedro
Sq.Ft.Grnd Area 2118

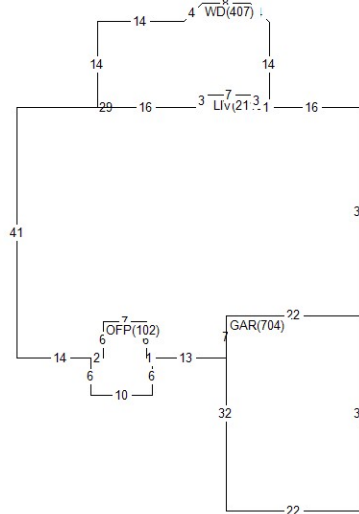

Land Value 32,000
Misc Value 40,820
Bldg Value 151,050
Total Value 223,870
Value By CAMA

RCN 165,987
Pct Good 0.9100
Obsol/Observed 0.0000
Building Value 151,050

DOCUMENT #	DATE	QS	SALE PRICE
318581	1007	U	
303425	0106	U	273,305

PERMIT NO	TYPE	DATE	AMOUNT
15752	86	1021	
12181	00	1207	
12181	01	0707	

Appraiser JB J. Brown
Appr Date 10/19/20
Use Code 0011 Imp. Farm
NBHD 406.50 1-5 RES W/O HSE L100 M100 B098

AREA	FLAT	EFF%	E/AREA	ACT%	A/AREA	EA/AA	HEATED
CONDR	900	1.00	900	1.00	900	900	
CRWL	18	1.00	18	1.00	18	18	
LIV	2118	1.00	2118	1.00	2118	2118	2118
GAR	704	1.00	704	1.00	704	704	
WD	407	1.00	407	1.00	407	407	
OFFP	102	1.00	102	1.00	102	102	

MISC BLDG CODE	DESC	LENGTH	WIDTH	UNITS	ADJ PRICE	EYB DT PCT	ADJUSTMENT	VALUE
1	1 OFFP	Open Frame Porch	.00	.00	102.00	26.86 2007 A 9.00	1.00	2,490
2	1 WD	Wood Deck	.00	.00	407.00	19.35 2007 A 9.00	1.00	7,170
3	1 CONDR	Concrete Drivewa	30.00	30.00	900.00	3.65 2007 A 9.00	1.00	2,990
4	1 BRVEN	Brick Veneer	.00	.00	744.00	14.65 2007 A 9.00	1.00	9,920
5	1 F-PS4C12	Pole Shd 4 Sde C	50.00	36.00	1800.00	13.25 2007 F3 76.50	1.00	5,610
6	2 F-PS4C12	Pole Shd 4 Sde C	60.00	36.00	2160.00	12.76 2007 F3 76.50	1.00	6,480

LAND LUSE DESC	ZONING	UNITS TP	PRICE	ADJUSTMENT	CODE/FACTOR	VALUE
1 CE County Road Cat.	MAL	2.50 R	12800.00	TW	1.00 .00 .00 .00	32,000

			COLUMBIA		IL 62236							
			Site Address: 000000		GILMORE LAKE		RD					
MISC	BLDG CODE	DESC	LENGTH	WIDTH	UNITS	ADJ	PRICE	EYB	DT	PCT	ADJUSTMENT	VALUE
7	2 F-PSCFL	Pole Shd Conc Fl	12.00	60.00	720.00		3.65	2007	F3	76.50	1.00	620
8	3 F-PS4C14	Pole Shd 4 Sde C	18.00	36.00	648.00		19.71	2007	F3	76.50	1.00	3,000
9	4 F-LTP	Lean-to Pole	36.00	11.00	396.00		7.25	2015	F3	40.50	1.00	1,710
10	5 F-PS4C08	Pole Shd 4 Sde C	10.00	10.00	100.00		16.36	2015	F3	40.50	1.00	970
11	3 F-PSNE	Pole Shd No Elec	18.00	36.00	648.00		.92	2007	F3	76.50	1.00	140-