

PART LOT 2A SUR 582

WATERLOO IL 62298

Site Address: 007543 OLD BLUFF RD

BLDG # 1
 Style/Stories 1.0 One Story
 Quality/Design C C-Average
 Building Use 0100 Single Fami
 Exterior Wall F Frame
 WALL % 100 100%
 Exterior Wall 1
 WALL 1% 000 N/A
 Crawl Sp. Adj C Crawl
 Slab Adjustment
 Basement
 Combination
 Attic Area
 Heat/AC Adj AC Central Air
 Comb Ht/AC Adj
 Fireplace 03 C-Fireplace
 Extra Fireplace 00 N/A
 Res Fixtures 0011 11 Fixtures
 Garage F Frame Garag
 Integral Garage
 Remodeling Adj 04 1/2 - 3/4 U
 Actual Year Blt 1980
 Effect Year Blt 1980
 Cond/Desir/Util A
 Township Multpl 06 TOWNSHIP #0
 Funct. Obs. % 000000
 Economic Obs. % 000000
 Observed Cond % 000000
 Obs. Cond. Code
 Combination A
 Comb A Ht/AC
 Unfin Low/Level
 Full Basement F Full Baseme
 # Of Bedrooms 04 Four Bedroo
 Sq.Ft.Grđ Area 1976

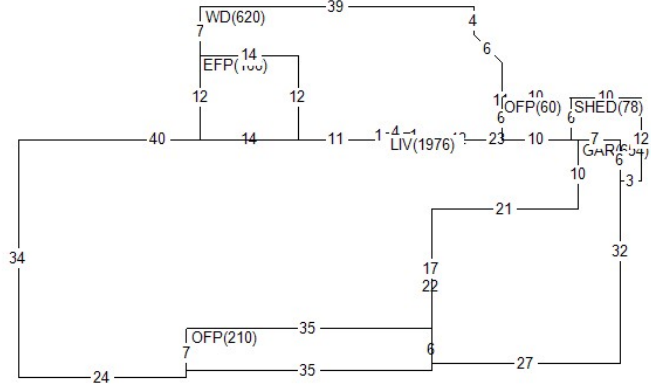

Land Value 9,000
 Misc Value 34,140
 Bldg Value 175,090
 Total Value 218,230
 Value By CAMA

RCN 269,374
 Pct Good 0.6500
 Obsol/Observed 0.0000
 Building Value 175,090

DOCUMENT # DATE QS SALE PRICE
 0794 U 75,000

PERMIT NO TYPE DATE AMOUNT

Appraiser JB J. Brown
 Appr Date 08/18/22
 Use Code 0040 Imp Res
 NBHD 1900.10 FLD PLN 60-NEW
 L100 M100 B170

AREA	FLAT	EFF% E/AREA	ACT% A/AREA	EA/AA HEATED
CRWL	5	1.00	5	5
CONDR	1808	1.00	1808	1808
EFP	168	1.00	168	168
WD	620	1.00	620	620
OFFP	270	1.00	270	270
GAR	654	1.00	654	654
LIV	1976	1.00	1976	1976
SHED	78	1.00	78	78
PTO	290	1.00	290	290

MISC BLDG CODE	DESC	LENGTH	WIDTH	UNITS	ADJ PRICE	EYB DT PCT	ADJUSTMENT	VALUE
1 1 BRVEN	Brick Veneer	.00	.00	572.00	14.65	1980 A 35.00	1.00	5,450
2 1 OFFP	Open Frame Porch	6.00	35.00	210.00	22.96	1980 A 35.00	1.00	3,130
3 1 EFP	Enclosed Fr. Por	12.00	14.00	168.00	40.88	1980 A 35.00	1.00	4,460
6 1 WD	Wood Deck	.00	.00	620.00	19.35	2003 A 12.00	1.00	10,560
7 1 CONDR	Concrete Drivewa	.00	.00	1808.00	3.65	2007 A 9.00	1.00	6,010
8 1 OFFP	Open Frame Porch	6.00	10.00	60.00	32.50	2007 A 9.00	1.00	1,780
LAND LUSE DESC	ZONING	UNITS TP	PRICE	ADJUSTMENT	CODE/FACTOR	ADJUSTMENT	VALUE	
1 CK County Road Cat.	MAL	4.00 R	3000.00	TW 1.00 CN	.75	.00	9,000	

MISC BLDG CODE	DESC	Site Address:	WATERLOO	OLD BLUFF	IL 62298	RD	ADJ PRICE	EYB DT	PCT	ADJUSTMENT	VALUE
		LENGTH	WIDTH	UNITS							
9 1 SHED	Frame Shed	.00	.00	78.00			26.75	2007 A	9.00	1.00	1,900
10 1 PTO	Concrete Patio	.00	.00	290.00			2.99	2019 A	2.00	.82	850