

LOT 384 NEW VALMEYER PHASE 6

VALMEYER IL 62295  
Site Address: 000320 W WOODLAND RIDGE

BLDG # 1  
 Style/Stories 2.0 2 Story  
 Quality/Design C C-Average  
 Building Use 0100 Single Fami  
 Exterior Wall M Masonry 2.0  
 WALL % 060 060%  
 Exterior Wall 1 F Frame  
 WALL 1% 040 040%  
 Crawl Sp. Adj  
 Slab Adjustment  
 Basement  
 Combination F1 Frame/1.0  
 Attic Area  
 Heat/AC Adj AC Central Air  
 Comb Ht/AC Adj AC1 Cent AC Cmb  
 Fireplace 33 2-DirectVen  
 Extra Fireplace 00 N/A  
 Res Fixtures 0013 13 Fixtures  
 Garage M Masonry Gar  
 Integral Garage  
 Remodeling Adj 01 No Remodeli  
 Actual Year Blt 2006  
 Effect Year Blt 2006  
 Cond/Desir/Util A Res CDU - A  
 Township Multpl 06 TOWNSHIP #0  
 Funct. Obs. % 000000  
 Economic Obs. % 000000  
 Observed Cond % 000000  
 Obs. Cond. Code  
 Combination A  
 Comb A Ht/AC  
 Unfin Low/Level  
 Full Basement F Full Baseme  
 # Of Bedrooms 03 Three Bedro  
 Sq.Ft.Grd Area 1767

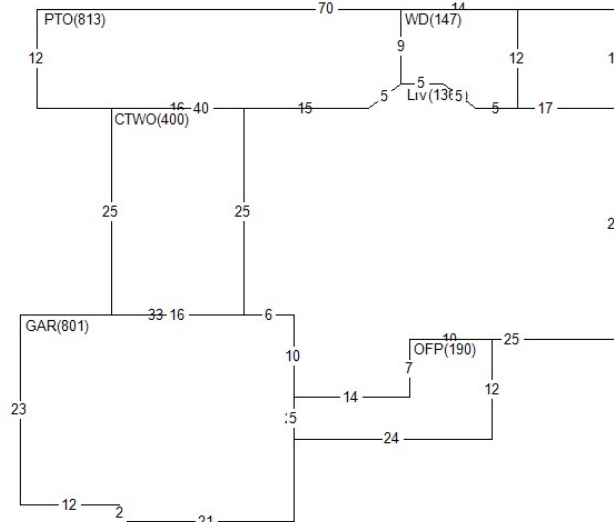

Land Value 26,760  
 Misc Value 16,100  
 Bldg Value 297,580  
 Total Value 340,440  
 Value By CAMA  
 RCN 330,648  
 Pct Good 0.9000  
 Obsol/Observed 0.0000  
 Building Value 297,580

DOCUMENT #	DATE	QS	SALE PRICE
369518	0114	U	169,190
363353	0313	U	
295878	0305	Q	43,500
PERMIT NO	TYPE	DATE	AMOUNT
R1-14-05	02	0914	
R1-05-34	01	1205	

Appraiser KS K. Sondag  
 Appr Date 07/05/22  
 Use Code 0040 Imp Res  
 NBHD 62000.20 VLMYR 2.0 STORY  
 L100 M100 B142

AREA	FLAT	EFF% E/AREA	ACT% A/AREA	EA/AA HEATED
CONDR	1097	1.00	1097	1097
GAR	801	1.00	801	801
OFFP	190	1.00	190	190
LIV	1367	1.00	1367	1367
CTWO	400	1.00	400	400
WD	147	1.00	147	147
PTO	813	1.00	813	813
SHED	140	1.00	140	140

MISC BLDG CODE	DESC	LENGTH	WIDTH	UNITS	ADJ PRICE	EYB DT PCT	ADJUSTMENT	VALUE
1	1 OFFP	0.00	0.00	190.00	23.02	2006 A 10.00	1.00	3,940
2	1 CONDR	0.00	0.00	1097.00	3.65	2006 A 10.00	1.00	3,600
3	1 WD	0.00	0.00	147.00	19.35	2009 A 7.00	1.00	2,650
4	1 PTO	0.00	0.00	813.00	2.99	2014 A 4.00	.82	2,340
5	1 SHED	14.00	10.00	140.00	26.54	2014 A 4.00	1.00	3,570

LAND LUSE DESC	ZONING	UNITS TP	PRICE	ADJUSTMENT	CODE/FACTOR	VALUE
1 6200 VALMEYER	VR1	1.00 ST	26760.00	TW 1.00	.00 .00 .00	26,760