

LOT 7 FOX RUN ESTATES PHASE 1

COLUMBIA IL 62236

Site Address: 002362 LAKE SHORE DR

BLDG # 1
 Style/Stories 1.0 One Story
 Quality/Design C C-Average
 Building Use 0100 Single Fami
 Exterior Wall F Frame
 WALL % 080 080%
 Exterior Wall 1 M Masonry
 WALL 1% 020 020%
 Crawl Sp. Adj
 Slab Adjustment
 Basement RC C-Rec Room
 Combination
 Attic Area
 Heat/AC Adj AC Central Air
 Comb Ht/AC Adj
 Fireplace 03 C-Fireplace
 Extra Fireplace 00 N/A
 Res Fixtures 0014 14 Fixtures
 Garage F Frame Garag
 Integral Garage
 Remodeling Adj 01 No Remodeli
 Actual Year Blt 2017
 Effect Year Blt 2017
 Cond/Desir/Util A Res CDU - A
 Township Multpl 04 TOWNSHIP #0
 Funct. Obs. % 000000
 Economic Obs. % 000000
 Observed Cond % 000000
 Obs. Cond. Code
 Combination A
 Comb A Ht/AC
 Unfin Low/Level
 Full Basement F Full Baseme
 # Of Bedrooms 03 Three Bedro
 Sq.Ft.Grd Area 1966

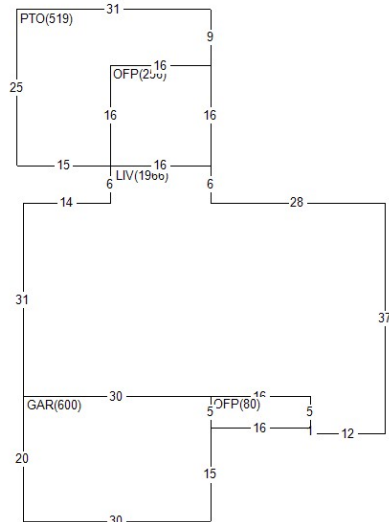

Land Value 62,100
 Misc Value 18,110
 Bldg Value 402,610
 Total Value 482,820
 Value By CAMA

RCN 410,830
 Pct Good 0.9800
 Obsol/Observed 0.0000
 Building Value 402,610

DOCUMENT #	DATE	QS	SALE PRICE
434417	0824	Q	550,300
392952	1117	Q	360,120
377969	0615	Q	500,000
PERMIT NO	TYPE	DATE	AMOUNT
BP-17-043	00	1017	
BP-17-043	01	0317	

Appraiser AS A. Schwar
 Appr Date 09/18/24
 Use Code 0040 Imp Res
 NBHD 411.39 FOX RUN EST 1.0
 L100 M100 B240

AREA	FLAT	EFF%	E/AREA	ACT%	A/AREA	EA/AA	HEATED
LIV	1966	1.00	1966	1.00	1966	1966	1966
OFFP	336	1.00	336	1.00	336	336	
GAR	600	1.00	600	1.00	600	600	
PTO	519	1.00	519	1.00	519	519	
BSMR	1100	1.00	1100	1.00	1100	1100	

MISC BLDG CODE	DESC	LENGTH	WIDTH	UNITS	ADJ PRICE	EYB DT	PCT	ADJUSTMENT	VALUE
1	1 OFFP	5.00	16.00	80.00	29.38	2017 A	2.00	1.00	2,300
2	1 OFFP	16.00	16.00	256.00	23.68	2017 A	2.00	1.00	5,940
3	1 PTO	.00	.00	519.00	3.65	2017 A	2.00	1.00	1,860
4	1 CONDR	48.00	26.00	1248.00	3.65	2017 A	2.00	1.00	4,460
5	1 BRVEN	.00	.00	247.00	14.65	2017 A	2.00	1.00	3,550

LAND LUSE DESC	ZONING	UNITS TP	PRICE	ADJUSTMENT	CODE/FACTOR	VALUE
1 0401 COLUMBIA LAND #1	CR5	19166.40 S	3.24	TW 1.00	.00 .00 .00	62,100