

Req By: DAWN  
NICHOLAS P WOJTAL  
2350 LAKE SHORE DRIVE

LOT 10 FOX RUN ESTATES PHASE 1

COLUMBIA IL 62236

Site Address: 002350 LAKE SHORE DR

BLDG # 1  
 Style/Stories 1.0 One Story  
 Quality/Design C C-Average  
 Building Use 0100 Single Fami  
 Exterior Wall F Frame  
 WALL % 080 080%  
 Exterior Wall 1 M Masonry  
 WALL 1% 020 020%  
 Crawl Sp. Adj  
 Slab Adjustment  
 Basement  
 Combination  
 Attic Area  
 Heat/AC Adj AC Central Air  
 Comb Ht/AC Adj  
 Fireplace 03 C-Fireplace  
 Extra Fireplace 00 N/A  
 Res Fixtures 0010 10 Fixtures  
 Garage F Frame Garag  
 Integral Garage  
 Remodeling Adj 01 No Remodeli  
 Actual Year Blt 2018  
 Effect Year Blt 2018  
 Cond/Desir/Util A Res CDU - A  
 Township Multpl 04 TOWNSHIP #0  
 Funct. Obs. % 000000  
 Economic Obs. % 000000  
 Observed Cond % 000000  
 Obs. Cond. Code  
 Combination A  
 Comb A Ht/AC  
 Unfin Low/Level  
 Full Basement F Full Baseme  
 # Of Bedrooms 03 Three Bedro  
 Sq.Ft.Grđ Area 1966

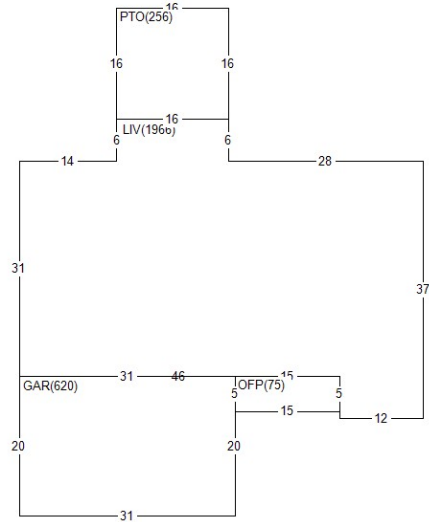

Land Value 62,530  
 Misc Value 12,020  
 Bldg Value 370,260  
 Total Value 444,810  
 Value By CAMA

RCN 377,815  
 Pct Good 0.9800  
 Obsol/Observed 0.0000  
 Building Value 370,260

DOCUMENT #	DATE	QS	SALE PRICE
395778	0518	Q	298,163
384686	0716	Q	795,000

PERMIT NO	TYPE	DATE	AMOUNT
BP-17-182	00	0418	
BP-17-182	01	1017	

Appraiser DG D. Goff  
 Appr Date 06/11/20  
 Use Code 0040 Imp Res  
 NBHD 411.39 FOX RUN EST 1.0  
 L100 M100 B240

AREA	FLAT	EFF%	E/AREA	ACT%	A/AREA	EA/AA	HEATED
LIV	1966	1.00	1966	1.00	1966	1966	1966
PTO	256	1.00	256	1.00	256	256	
GAR	620	1.00	620	1.00	620	620	
OFF	75	1.00	75	1.00	75	75	
CONDR	1519	1.00	1519	1.00	1519	1519	

MISC BLDG CODE	DESC	LENGTH	WIDTH	UNITS	ADJ PRICE	EYB DT	PCT	ADJUSTMENT	VALUE
1 1 OFF	Open Frame Porch	5.00	15.00	75.00	30.16	2018 A	2.00	1.00	2,220
2 1 PTO	Concrete Patio	16.00	16.00	256.00	3.65	2018 A	2.00	1.00	920
3 1 CONDR	Concrete Drivewa	49.00	31.00	1519.00	3.65	2018 A	2.00	1.00	5,430
4 1 BRVEN	Brick Veneer	.00	.00	240.00	14.65	2018 A	2.00	1.00	3,450

LAND LUSE DESC	ZONING	UNITS TP	PRICE	ADJUSTMENT	CODE/FACTOR	VALUE
1 0401 COLUMBIA LAND #1	CR5	19602.00 S	3.19	TW 1.00	.00 .00	62,530