

Req By: DAWN
RYAN SPITZ &
MOLLY DIEHL
2338 LAKE SHORE DRIVE

LOT 13 FOX RUN ESTATES PHASE 1

COLUMBIA IL 62236

Site Address: 002338 LAKE SHORE DR

BLDG # 1
 Style/Stories 1.0 One Story
 Quality/Design C C-Average
 Building Use 0100 Single Fami
 Exterior Wall F Frame
 WALL % 080 080%
 Exterior Wall 1 M Masonry
 WALL 1% 020 020%
 Crawl Sp. Adj
 Slab Adjustment
 Basement
 Combination
 Attic Area
 Heat/AC Adj AC Central Air
 Comb Ht/AC Adj
 Fireplace C-Fireplace
 Extra Fireplace 00 N/A
 Res Fixtures 0009 09 Fixtures
 Garage F Frame Garag
 Integral Garage
 Remodeling Adj 01 No Remodeli
 Actual Year Blt 2018
 Effect Year Blt 2018
 Cond/Desir/Util A Res CDU - A
 Township Multpl 04 TOWNSHIP #0
 Funct. Obs. % 000000
 Economic Obs. % 000000
 Observed Cond % 000000
 Obs. Cond. Code
 Combination A
 Comb A Ht/AC
 Unfin Low/Level
 Full Basement F Full Baseme
 # Of Bedrooms 03 Three Bedro
 Sq.Ft.Grđ Area 1669

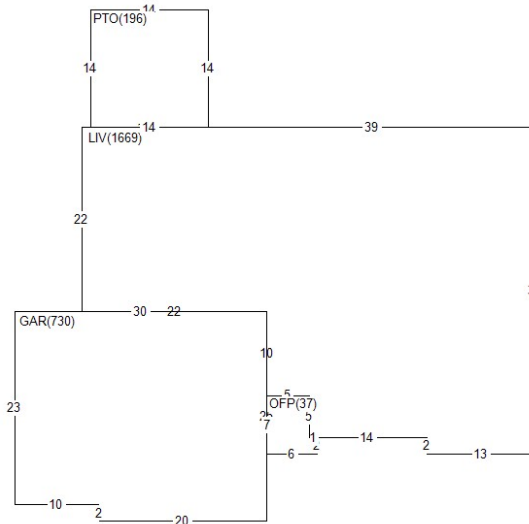

Land Value 59,120
 Misc Value 9,830
 Bldg Value 333,630
 Total Value 402,580
 Value By CAMA

RCN 340,440
 Pct Good 0.9800
 Obsol/Observed 0.0000
 Building Value 333,630

DOCUMENT #	DATE	QS	SALE PRICE
400061	0219	Q	285,500
384686	0716	Q	795,000

PERMIT NO	TYPE	DATE	AMOUNT
BP-18-033	00	0219	
BP-18-033	01	0318	

Appraiser DG D. Goff
 Appr Date 06/11/20
 Use Code 0040 Imp Res
 NBHD 411.39 FOX RUN EST 1.0
 L100 M100 B240

	AREA	FLAT	EFF% E/AREA	ACT% A/AREA	EA/AA	HEATED
LIV	1669	1.00	1669	1.00	1669	1669
PTO	196	1.00	196	1.00	196	196
GAR	730	1.00	730	1.00	730	730
OFP	37	1.00	37	1.00	37	37
CONDR	1290	1.00	1290	1.00	1290	1290

MISC BLDG CODE	DESC	LENGTH	WIDTH	UNITS	ADJ PRICE	EYB DT PCT	ADJUSTMENT	VALUE
1	1 OFP	Open Frame Porch	.00	.00	37.00	42.00 2018 A 2.00	1.00	1,520
2	1 PTO	Concrete Patio	14.00	14.00	196.00	3.65 2018 A 2.00	1.00	700
3	1 CONDR	Concrete Drivewa	.00	.00	1290.00	3.65 2018 A 2.00	1.00	4,620
4	1 BRVEN	Brick Veneer	.00	.00	208.00	14.65 2018 A 2.00	1.00	2,990

LAND LUSE DESC	ZONING	UNITS TP	PRICE	ADJUSTMENT	CODE/FACTOR	VALUE
1 0401 COLUMBIA LAND #1	CR5	15681.60 S	3.77	TW 1.00	.00 .00	59,120