

Req By: DAWN
JOB GEORGE &
ALPHONSAMMA JOB TRUST
321 FOX RUN DRIVE

LOT 24 FOX RUN ESTATES PHASE 2

COLUMBIA IL 62236

Site Address: 000321 FOX RUN DR

BLDG # 1
Style/Stories 1.0 One Story
Quality/Design C C-Average
Building Use 0100 Single Fami
Exterior Wall F Frame
WALL % 080 080%
Exterior Wall 1 M Masonry
WALL 1% 020 020%
Crawl Sp. Adj C Crawl
Slab Adjustment
Basement LC C-Living Qt
Combination
Attic Area
Heat/AC Adj AC Central Air
Comb Ht/AC Adj
Fireplace 00 N/A
Extra Fireplace 00 N/A
Res Fixtures 0013 13 Fixtures
Garage F Frame Garag
Integral Garage
Remodeling Adj 01 No Remodeli
Actual Year Blt 2017
Effect Year Blt 2017
Cond/Desir/Util A Res CDU - A
Township Multpl 04 TOWNSHIP #0
Funct. Obs. % 000000
Economic Obs. % 000000
Observed Cond % 000000
Obs. Cond. Code
Combination A
Comb A Ht/AC
Unfin Low/Level
Full Basement F Full Baseme
Of Bedrooms 03 Three Bedro
Sq.Ft.Grnd Area 1654

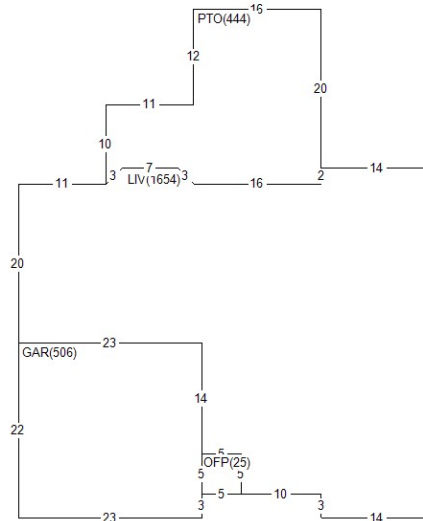

Land Value 55,750
Misc Value 6,400
Bldg Value 338,570
Total Value 400,720
Value By CAMA

RCN 345,480
Pct Good 0.9800
Obsol/Observed 0.0000
Building Value 338,570

Table with columns: DOCUMENT #, DATE, QS, SALE PRICE. Includes entries for 430477, 391790, 384686 and permit information for BP-17-048.

Appraiser AS A. Schwar
Apr Date 10/05/23
Use Code 0040 Imp Res
NBHD 411.39 FOX RUN EST 1.0
L100 M100 B240

Table with columns: AREA, FLAT, EFF% E/AREA, ACT% A/AREA, EA/AA HEATED. Lists areas like LIV, GAR, OFP, PTO, CONDR, CRWL, BSML.

Table with columns: MISC BLDG CODE, DESC, LENGTH, WIDTH, UNITS, ADJ PRICE, EYB DT PCT, ADJUSTMENT, VALUE. Lists items like Concrete Patio, Concrete Drivewa, Brick Veneer.

Table with columns: LAND LUSE DESC, ZONING, UNITS TP, PRICE, ADJUSTMENT CODE/FACTOR, VALUE. Shows land use 0401 COLUMBIA LAND #1 with price 4.74.