

Req By: DAWN
ROBERT & MARY MEYER
309 FOX RUN DRIVE

LOT 27 FOX RUN ESTATES PHASE 2

COLUMBIA IL 62236

Site Address: 000309 FOX RUN DR

BLDG # 1
 Style/Stories 1.0 One Story
 Quality/Design C C-Average
 Building Use 0100 Single Fami
 Exterior Wall F Frame
 WALL % 080 080%
 Exterior Wall 1 M Masonry
 WALL 1% 020 020%
 Crawl Sp. Adj
 Slab Adjustment
 Basement LC C-Living Qt
 Combination
 Attic Area
 Heat/AC Adj AC Central Air
 Comb Ht/AC Adj
 Fireplace 00 N/A
 Extra Fireplace 00 N/A
 Res Fixtures 0011 11 Fixtures
 Garage F Frame Garag
 Integral Garage
 Remodeling Adj 01 No Remodeli
 Actual Year Blt 2019
 Effect Year Blt 2019
 Cond/Desir/Util A
 Township Multpl 04 TOWNSHIP #0
 Funct. Obs. % 000000
 Economic Obs. % 000000
 Observed Cond % 000000
 Obs. Cond. Code
 Combination A
 Comb A Ht/AC
 Unfin Low/Level
 Full Basement F Full Baseme
 # Of Bedrooms 04 Four Bedroo
 Sq.Ft.Grđ Area 1648

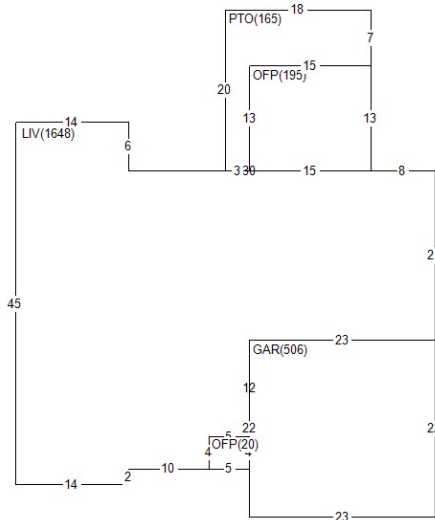

Land Value 55,000
 Misc Value 10,060
 Bldg Value 325,510
 Total Value 390,570
 Value By CAMA

RCN 332,150
 Pct Good 0.9800
 Obsol/Observed 0.0000
 Building Value 325,510

DOCUMENT #	DATE	QS	SALE PRICE
399930	0219	Q	298,547
384686	0716	U	795,000

PERMIT NO	TYPE	DATE	AMOUNT
20-4647	07	0220	
HOP-19-021	00	0119	
BP-18-127	01	0718	

Appraiser RM R. Mueller
 Apr Date 11/08/21
 Use Code 0040 Imp Res
 NBHD 411.39 FOX RUN EST 1.0
 L100 M100 B240

AREA	FLAT	EFF% E/AREA	ACT% A/AREA	EA/AA HEATED
LIV	1648	1.00	1648	1648
GAR	506	1.00	506	506
COND	799	1.00	799	799
BSML	500	1.00	500	500
OFP	215	1.00	215	215
PTO	165	1.00	165	165

MISC BLDG CODE	DESC	LENGTH	WIDTH	UNITS	ADJ PRICE	EYB DT PCT	ADJUSTMENT	VALUE
1 1 CONDR	Concrete Drivewa	47.00	17.00	799.00	3.65	2019 A 2.00	1.00	2,860
2 1 BRVEN	Brick Veneer	.00	.00	152.00	14.65	2019 A 2.00	1.00	2,180
3 1 OFP	Open Frame Porch	13.00	15.00	195.00	22.89	2020 A 1.00	1.00	4,420
4 1 PTO	Concrete Patio	.00	.00	165.00	3.65	2020 A 1.00	1.00	600

LAND LUSE DESC	ZONING	UNITS TP	PRICE	ADJUSTMENT	CODE/FACTOR	VALUE
1 0401 COLUMBIA LAND #1	CR5	10890.00 S	5.05	TW 1.00	.00 .00	55,000