

LOT 33 FOX RUN ESTATES PHASE 2

COLUMBIA IL 62236

Site Address: 000312 FOX RUN DR

BLDG # 1  
 Style/Stories 1.0 One Story  
 Quality/Design C C-Average  
 Building Use 0100 Single Fami  
 Exterior Wall F Frame  
 WALL % 080 080%  
 Exterior Wall 1 M Masonry  
 WALL 1% 020 020%  
 Crawl Sp. Adj C Crawl  
 Slab Adjustment  
 Basement LC C-Living Qt  
 Combination  
 Attic Area  
 Heat/AC Adj AC Central Air  
 Comb Ht/AC Adj  
 Fireplace  
 Extra Fireplace 00 N/A  
 Res Fixtures 0014 14 Fixtures  
 Garage F Frame Garag  
 Integral Garage  
 Remodeling Adj 01 No Remodeli  
 Actual Year Blt 2017  
 Effect Year Blt 2017  
 Cond/Desir/Util A Res CDU - A  
 Township Multpl 04 TOWNSHIP #0  
 Funct. Obs. % 000000  
 Economic Obs. % 000000  
 Observed Cond % 000000  
 Obs. Cond. Code  
 Combination A  
 Comb A Ht/AC  
 Unfin Low/Level  
 Full Basement F Full Baseme  
 # Of Bedrooms 03 Three Bedro  
 Sq.Ft.Grđ Area 1781

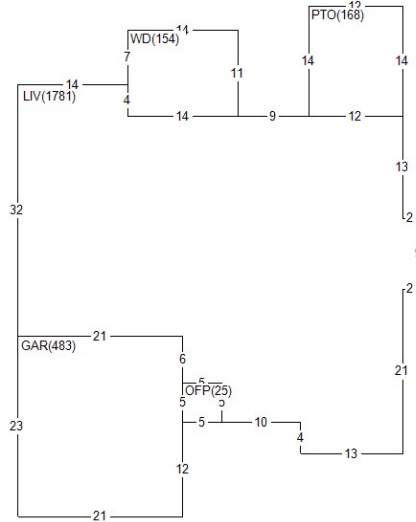

Land Value 64,030  
 Misc Value 14,840  
 Bldg Value 364,260  
 Total Value 443,130  
 Value By CAMA

RCN 371,698  
 Pct Good 0.9800  
 Obsol/Observed 0.0000  
 Building Value 364,260

DOCUMENT #	DATE	QS	SALE PRICE
406110	0220	U	
388978	0317	Q	335,710
386612	1116	Q	53,000
PERMIT NO	TYPE	DATE	AMOUNT
BP-16-194	00	0417	
BP-16-194	01	1116	

Appraiser DG D. Goff  
 Appr Date 06/11/20  
 Use Code 0040 Imp Res  
 NBHD 411.39 FOX RUN EST 1.0  
 L100 M100 B240

AREA	FLAT	EFF%	E/AREA	ACT%	A/AREA	EA/AA	HEATED
LIV	1781	1.00	1781	1.00	1781	1781	1781
WD	154	1.00	154	1.00	154	154	
PTO	168	1.00	168	1.00	168	168	
OFF	25	1.00	25	1.00	25	25	
GAR	483	1.00	483	1.00	483	483	
CONDR	1396	1.00	1396	1.00	1396	1396	
CRWL	18	1.00	18	1.00	18	18	
BSML	705	1.00	705	1.00	705	705	

MISC BLDG CODE	DESC	LENGTH	WIDTH	UNITS	ADJ PRICE	EYB DT PCT	ADJUSTMENT	VALUE
1 1 WD	Wood Deck	11.00	14.00	154.00	19.35	2017 A 2.00	1.00	2,920
2 1 PTO	Concrete Patio	14.00	12.00	168.00	3.65	2017 A 2.00	1.00	600
3 1 CONDR	Concrete Drivewa	.00	.00	1396.00	3.65	2017 A 2.00	1.00	4,990
4 1 BRVEN	Brick Veneer	.00	.00	312.00	14.65	2017 A 2.00	1.00	4,480
5 1 DORM	Dormer	.00	.00	1.00	1850.00	2017 OD 0.00	1.00	1,850

LAND LUSE DESC	ZONING	UNITS TP	PRICE	ADJUSTMENT	CODE/FACTOR	VALUE
1 0401 COLUMBIA LAND #1	CR5	21344.40 S	3.00	TW 1.00	.00 .00 .00	64,030