

Req By: DAWN
CHARLES R ROBERTS &
ALISHA D PATRICK
330 FOX RUN DRIVE

LOT 36 FOX RUN ESTATES PHASE 2

COLUMBIA IL 62236

Site Address: 000330 FOX RUN DR

BLDG # 1
 Style/Stories 1.0 One Story
 Quality/Design C C-Average
 Building Use 0100 Single Fami
 Exterior Wall F Frame
 WALL % 080 080%
 Exterior Wall 1 M Masonry
 WALL 1% 020 020%
 Crawl Sp. Adj
 Slab Adjustment
 Basement
 Combination
 Attic Area
 Heat/AC Adj AC Central Air
 Comb Ht/AC Adj
 Fireplace 00 N/A
 Extra Fireplace 00 N/A
 Res Fixtures 0010 10 Fixtures
 Garage M Masonry Gar
 Integral Garage
 Remodeling Adj 01 No Remodeli
 Actual Year Blt 2017
 Effect Year Blt 2017
 Cond/Desir/Util A Res CDU - A
 Township Multpl 04 TOWNSHIP #0
 Funct. Obs. % 000000
 Economic Obs. % 000000
 Observed Cond % 000000
 Obs. Cond. Code
 Combination A
 Comb A Ht/AC
 Unfin Low/Level
 Full Basement F Full Baseme
 # Of Bedrooms 03 Three Bedro
 Sq.Ft.Grnd Area 1946

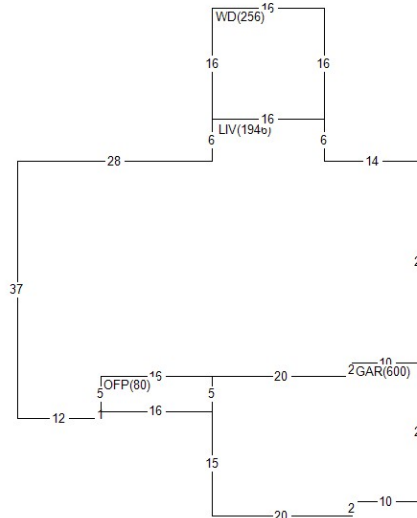

Land Value 62,920
 Misc Value 11,760
 Bldg Value 361,260
 Total Value 435,940
 Value By CAMA

RCN 368,633
 Pct Good 0.9800
 Obsol/Observed 0.0000
 Building Value 361,260

DOCUMENT #	DATE	QS	SALE PRICE
393792	0118	Q	323,567
384686	0716	U	795,000

PERMIT NO	TYPE	DATE	AMOUNT
20-6283	08	1020	
20-6282	21	1020	
BP-17-087	00	1217	

Appraiser DG D. Goff
 Appr Date 06/11/20
 Use Code 0040 Imp Res
 NBHD 411.39 FOX RUN EST 1.0
 L100 M100 B240

AREA	FLAT	EFF%	E/AREA	ACT%	A/AREA	EA/AA	HEATED
LIV	1946	1.00	1946	1.00	1946	1946	1946
WD	256	1.00	256	1.00	256	256	
OFF	80	1.00	80	1.00	80	80	
GAR	600	1.00	600	1.00	600	600	
CONDR	1287	1.00	1287	1.00	1287	1287	

MISC BLDG CODE	DESC	LENGTH	WIDTH	UNITS	ADJ PRICE	EYB DT	PCT	ADJUSTMENT	VALUE
1 1 OFP	Open Frame Porch	5.00	16.00	80.00	29.38	2017 A	2.00	1.00	2,300
2 1 WD	Wood Deck	16.00	16.00	256.00	19.35	2017 A	2.00	1.00	4,860
3 1 CONDR	Concrete Drivewa	.00	.00	1287.00	3.65	2017 A	2.00	1.00	4,600

LAND LUSE DESC	ZONING	UNITS TP	PRICE	ADJUSTMENT	CODE/FACTOR	VALUE
1 0401 COLUMBIA LAND #1	CR5	20037.60 S	3.14 TW	1.00	.00 .00	62,920