

LOT 39 FOX RUN ESTATES PHASE 3

COLUMBIA IL 62236

Site Address: 002339 LAKE SHORE DR

BLDG # 1
Style/Stories 1.0 One Story
Quality/Design C C-Average
Building Use 0100 Single Fami
Exterior Wall F Frame
WALL % 080 080%
Exterior Wall 1 M Masonry
WALL 1% 020 020%
Crawl Sp. Adj
Slab Adjustment
Basement LC C-Living Qt
Combination
Attic Area
Heat/AC Adj AC Central Air
Comb Ht/AC Adj
Fireplace 31 DirectVent
Extra Fireplace 00 N/A
Res Fixtures 0010 10 Fixtures
Garage F Frame Garag
Integral Garage
Remodeling Adj 01 No Remodeli
Actual Year Blt 2018
Effect Year Blt 2018
Cond/Desir/Util A Res CDU - A
Township Multpl 04 TOWNSHIP #0
Funct. Obs. % 000000
Economic Obs. % 000000
Observed Cond % 000000
Obs. Cond. Code
Combination A
Comb A Ht/AC
Unfin Low/Level
Full Basement F Full Baseme
Of Bedrooms 03 Three Bedro
Sq.Ft.Grnd Area 1762

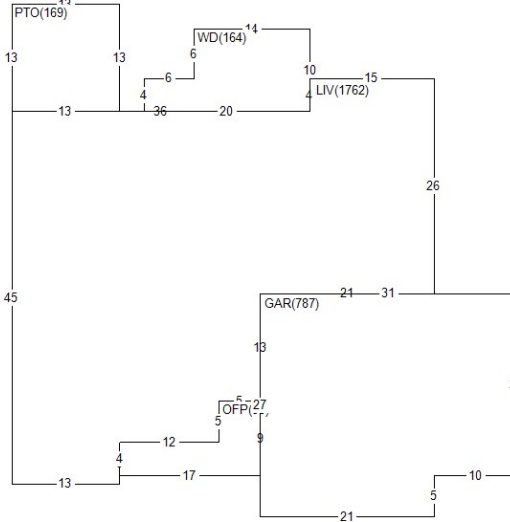

Land Value 58,350
Misc Value 17,880
Bldg Value 358,890
Total Value 435,120
Value By CAMA

RCN 366,218
Pct Good 0.9800
Obsol/Observed 0.0000
Building Value 358,890

DOCUMENT # DATE QS SALE PRICE

PERMIT NO TYPE DATE AMOUNT
BP-17-105 00 0218
BP-17-105 01 0717

Appraiser DG D. Goff
Appr Date 06/11/20
Use Code 0040 Imp Res
NBHD 411.39 FOX RUN EST 1.0
L100 M100 B240

AREA	FLAT	EFF%	E/AREA	ACT%	A/AREA	EA/AA	HEATED
LIV	1762	1.00	1762	1.00	1762	1762	1762
OFF	93	1.00	93	1.00	93	93	
GAR	787	1.00	787	1.00	787	787	
PTO	351	1.00	351	1.00	351	351	
WD	164	1.00	164	1.00	164	164	
CONDR	1618	1.00	1618	1.00	1618	1618	
BSML	675	1.00	675	1.00	675	675	

MISC BLDG CODE	DESC	LENGTH	WIDTH	UNITS	ADJ PRICE	EYB DT	PCT	ADJUSTMENT	VALUE
1 1 OFP	Open Frame Porch	.00	.00	93.00	27.83	2018 A	2.00	1.00	2,540
2 1 PTO	Concrete Patio	13.00	13.00	169.00	3.65	2018 A	2.00	1.00	610
3 1 WD	Wood Deck	.00	.00	164.00	19.35	2018 A	2.00	1.00	3,110
4 1 PTO	Concrete Patio	13.00	14.00	182.00	3.65	2018 A	2.00	1.00	650
5 1 CONDR	Concrete Drivewa	.00	.00	1618.00	3.65	2018 A	2.00	1.00	5,790
6 1 BRVEN	Brick Veneer	.00	.00	232.00	14.65	2018 A	2.00	1.00	3,330
LAND LUSE DESC	ZONING	UNITS	TP	PRICE	ADJUSTMENT	CODE/FACTOR	ADJUSTMENT	VALUE	
1 0401 COLUMBIA LAND #1	CR5	14810.40	S	3.94	TW	1.00	.00	.00	58,350

Req By: DAWN
ADMIRAL PARKWAY INC
PO BOX 140

MISC BLDG CODE	DESC	Site Address:	COLUMBIA	LAKE SHORE	IL 62236	DR	EYB DT PCT	ADJUSTMENT	VALUE
		LENGTH	WIDTH	UNITS	ADJ PRICE				
7 1 DORM	Dormer	.00	.00	1.00	1850.00	2018 OD	0.00	1.00	1,850