

LOT 45 FOX RUN ESTATES PHASE 3

COLUMBIA IL 62236

Site Address: 002331 LAKE SHORE DR

BLDG # 1
 Style/Stories 1.0 One Story
 Quality/Design C C-Average
 Building Use 0100 Single Fami
 Exterior Wall F Frame
 WALL % 100 100%
 Exterior Wall 1
 WALL 1% 000 N/A
 Crawl Sp. Adj
 Slab Adjustment
 Basement
 Combination
 Attic Area
 Heat/AC Adj AC Central Air
 Comb Ht/AC Adj
 Fireplace N/A
 Extra Fireplace 00 N/A
 Res Fixtures 0009 09 Fixtures
 Garage F Frame Garag
 Integral Garage
 Remodeling Adj 01 No Remodeli
 Actual Year Blt 2021
 Effect Year Blt 2021
 Cond/Desir/Util A Res CDU - A
 Township Multpl 04 TOWNSHIP #0
 Funct. Obs. % 000000
 Economic Obs. % 000000
 Observed Cond % 000000
 Obs. Cond. Code
 Combination A
 Comb A Ht/AC
 Unfin Low/Level
 Full Basement F Full Baseme
 # Of Bedrooms 03 Three Bedro
 Sq.Ft.Grnd Area 1861

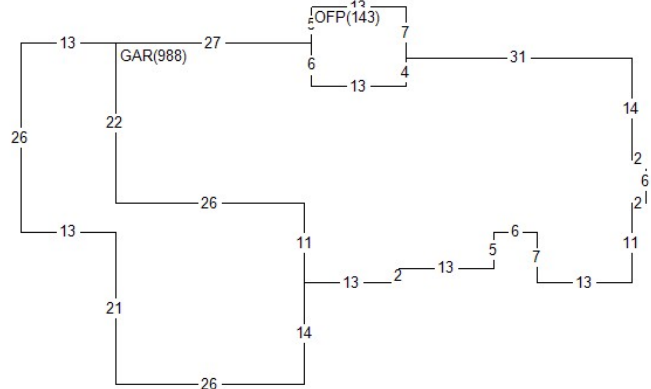

Land Value 113,990
 Misc Value 27,380
 Bldg Value 356,960
 Total Value 498,330
 Value By CAMA

RCN 360,566
 Pct Good 0.9900
 Obsol/Observed 0.0000
 Building Value 356,960

DOCUMENT #	DATE	QS	SALE PRICE
414279	0121	U	371,728
395060	0318	Q	54,000

PERMIT NO	TYPE	DATE	AMOUNT
1233	00	0121	
20-4806	01	0520	

Appraiser KK K. Kenned
 Appr Date 11/16/22
 Use Code 0040 Imp Res
 NBHD 411.39 FOX RUN EST 1.0
 L100 M100 B240

AREA	FLAT	EFF%	E/AREA	ACT%	A/AREA	EA/AA	HEATED
LIV	1861	1.00	1861	1.00	1861	1861	1861
GAR	988	1.00	988	1.00	988	988	
OFFP	143	1.00	143	1.00	143	143	
CONDR	1312	1.00	1312	1.00	1312	1312	
ASP	4510	1.00	4510	1.00	4510	4510	

MISC BLDG CODE	DESC	LENGTH	WIDTH	UNITS	ADJ PRICE	EYB DT	PCT	ADJUSTMENT	VALUE
1 1	OFFP	13.00	11.00	143.00	24.34	2021 A	1.00	1.00	3,450
2 1	BRVEN	.00	.00	318.00	14.65	2021 A	1.00	1.00	4,610
3 1	DORM	.00	.00	1.00	1850.00	2021 OD	0.00	1.00	1,850
4 1	CONDR	.00	.00	1312.00	3.65	2021 A	1.00	1.00	4,740
5 1	ASP	.00	.00	4510.00	2.85	2021 A	1.00	1.00	12,730

LAND LUSE DESC	ZONING	UNITS TP	PRICE	ADJUSTMENT	CODE/FACTOR	VALUE
1 0401 COLUMBIA LAND #1	CR5	79714.80 S	1.43	TW 1.00	.00 .00 .00	113,990