

LOT 42 FOX RUN ESTATES PHASE 3

COLUMBIA IL 62236

Site Address: 002351 LAKE SHORE DR

BLDG # 1
 Style/Stories 1.0 One Story
 Quality/Design C C-Average
 Building Use 0100 Single Fami
 Exterior Wall F Frame
 WALL % 075 075%
 Exterior Wall 1 M Masonry
 WALL 1% 025 025%
 Crawl Sp. Adj
 Slab Adjustment
 Basement LC C-Living Qt
 Combination
 Attic Area
 Heat/AC Adj AC Central Air
 Comb Ht/AC Adj
 Fireplace 31 DirectVent
 Extra Fireplace 00 N/A
 Res Fixtures 0017 17 Fixtures
 Garage F Frame Garag
 Integral Garage
 Remodeling Adj 01 No Remodeli
 Actual Year Blt 2019
 Effect Year Blt 2019
 Cond/Desir/Util A Res CDU - A
 Township Multpl 04 TOWNSHIP #0
 Funct. Obs. % 000000
 Economic Obs. % 000000
 Observed Cond % 000000
 Obs. Cond. Code
 Combination A
 Comb A Ht/AC
 Unfin Low/Level
 Full Basement F Full Baseme
 # Of Bedrooms 04 Four Bedroo
 Sq.Ft.Grđ Area 1859

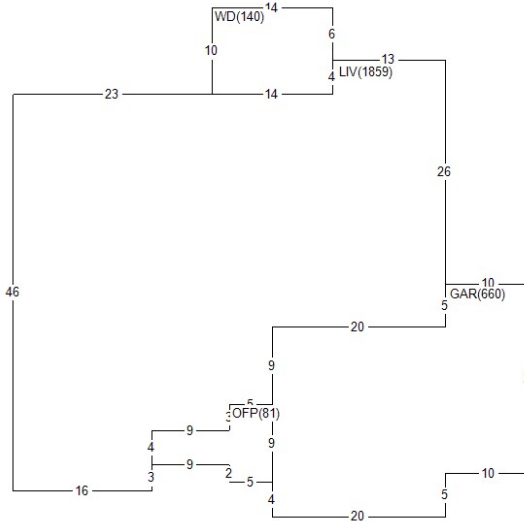

Land Value 55,380
 Misc Value 14,960
 Bldg Value 403,600
 Total Value 473,940
 Value By CAMA

RCN 411,838
 Pct Good 0.9800
 Obsol/Observed 0.0000
 Building Value 403,600

DOCUMENT #	DATE	QS	SALE PRICE
429447	0623	Q	415,000
402638	0719	U	381,437
395645	0518	U	60,000
PERMIT NO	TYPE	DATE	AMOUNT
BP-18-149	01	0818	

Appraiser AS A. Schwar
 Appr Date 08/08/23
 Use Code 0040 Imp Res
 NBHD 411.39 FOX RUN EST 1.0
 L100 M100 B240

AREA	FLAT	EFF% E/AREA	ACT% A/AREA	EA/AA HEATED
LIV	1859	1.00	1859 1.00	1859 1859
GAR	660	1.00	660 1.00	660 660
OFFP	81	1.00	81 1.00	81 81
WD	140	1.00	140 1.00	140 140
CONDR	1265	1.00	1265 1.00	1265 1265
PTO	140	1.00	140 1.00	140 140
BSML	1200	1.00	1200 1.00	1200 1200

MISC BLDG CODE	DESC	LENGTH	WIDTH	UNITS	ADJ PRICE	EYB DT PCT	ADJUSTMENT	VALUE
1 1 OFP	Open Frame Porch	.00	.00	81.00	29.26	2019 A 2.00	1.00	2,320
2 1 WD	Wood Deck	14.00	10.00	140.00	19.35	2019 A 2.00	1.00	2,660
3 1 CONDR	Concrete Drivewa	.00	.00	1265.00	3.65	2019 A 2.00	1.00	4,530
4 1 DORM	Dormer	.00	.00	1.00	1850.00	2019 OD 0.00	1.00	1,850
5 1 BRVEN	Brick Veneer	.00	.00	216.00	14.65	2019 A 2.00	1.00	3,100
6 1 PTO	Concrete Patio	14.00	10.00	140.00	3.65	2019 A 2.00	1.00	500
LAND LUSE DESC	ZONING	UNITS TP	PRICE	ADJUSTMENT	CODE/FACTOR	ADJUSTMENT	VALUE	
1 0401 COLUMBIA LAND #1	CR5	11325.60 S	4.89	TW 1.00	.00	.00	55,380	