

Req By: DAWN
KRISTIN NELSON &
COREY A CROWDER
2359 LAKE SHORE DR

LOT 44 FOX RUN ESTATES PHASE 3

COLUMBIA IL 62236

Site Address: 002359 LAKE SHORE DR

BLDG # 1
 Style/Stories 1.0 One Story
 Quality/Design C C-Average
 Building Use 0100 Single Fami
 Exterior Wall F Frame
 WALL % 080 080%
 Exterior Wall 1 M Masonry
 WALL 1% 020 020%
 Crawl Sp. Adj
 Slab Adjustment
 Basement LC C-Living Qt
 Combination
 Attic Area
 Heat/AC Adj AC Central Air
 Comb Ht/AC Adj
 Fireplace 03 C-Fireplace
 Extra Fireplace 00 N/A
 Res Fixtures 0014 14 Fixtures
 Garage F Frame Garag
 Integral Garage
 Remodeling Adj 01 No Remodeli
 Actual Year Blt 2020
 Effect Year Blt 2020
 Cond/Desir/Util A Res CDU - A
 Township Multpl 04 TOWNSHIP #0
 Funct. Obs. % 000000
 Economic Obs. % 000000
 Observed Cond % 000000
 Obs. Cond. Code
 Combination A
 Comb A Ht/AC
 Unfin Low/Level
 Full Basement F Full Baseme
 # Of Bedrooms 04 Four Bedroo
 Sq.Ft.Grđ Area 1839

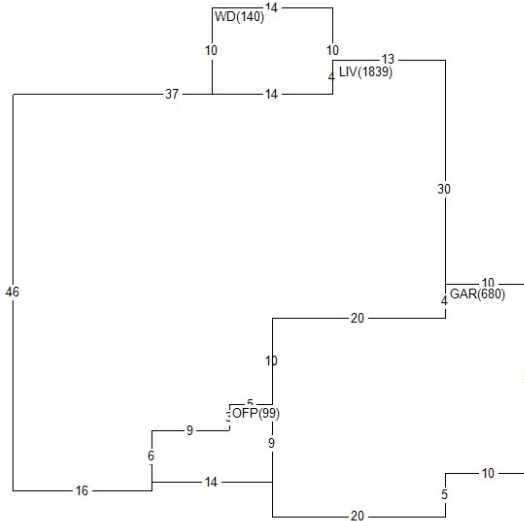

Land Value 55,380
 Misc Value 26,800
 Bldg Value 390,560
 Total Value 472,740
 Value By CAMA

RCN 394,505
 Pct Good 0.9900
 Obsol/Observed 0.0000
 Building Value 390,560

DOCUMENT #	DATE	QS	SALE PRICE
433637	0624	U	490,000
411068	0920	Q	413,500
394738	0318	Q	60,000
PERMIT NO	TYPE	DATE	AMOUNT
1215	00	0720	
BP-18-084	01	0518	

Appraiser AS A. Schwar
 Appr Date 08/01/24
 Use Code 0040 Imp Res
 NBHD 411.39 FOX RUN EST 1.0
 L100 M100 B240

AREA	FLAT	EFF% E/AREA	ACT% A/AREA	EA/AA HEATED
LIV	1839	1.00	1839 1.00	1839 1839
GAR	680	1.00	680 1.00	680 680
OFF	99	1.00	99 1.00	99 99
WD	140	1.00	140 1.00	140 140
BSML	892	1.00	892 1.00	892 892
PTO	140	1.00	140 1.00	140 140
CONDR	1280	1.00	1280 1.00	1280 1280

MISC BLDG CODE	DESC	LENGTH	WIDTH	UNITS	ADJ PRICE	EYB DT PCT	ADJUSTMENT	VALUE
1 1 OFFP	Open Frame Porch	.00	.00	99.00	27.12	2020 A 1.00	1.00	2,660
2 1 WD	Wood Deck	10.00	14.00	140.00	19.35	2020 A 1.00	1.00	2,680
3 1 PTO	Concrete Patio	10.00	14.00	140.00	3.65	2020 A 1.00	1.00	510
4 1 CONDR	Concrete Drivewa	.00	.00	1280.00	3.65	2020 A 1.00	1.00	4,630
5 1 BRVEN	Brick Veneer	.00	.00	1125.00	14.65	2020 A 1.00	1.00	16,320

LAND LUSE DESC	ZONING	UNITS TP	PRICE	ADJUSTMENT	CODE/FACTOR	VALUE
1 0401 COLUMBIA LAND #1	CR5	11325.60 S	4.89	TW 1.00	.00 .00 .00	55,380